

Astronomy Merit Badge



Troop 344/9344
Pemberville, OH





Astronomy Merit Badge Requirements

1. Do the following:
 - a. Explain to your counselor the most likely hazards you may encounter while participating in astronomy activities, and what you should do to anticipate, help prevent, mitigate, and respond to these hazards.
 - b. Explain first aid for injuries or illnesses such as heat and cold reactions, dehydration, bites and stings, and damage to your eyes that could occur during observation.
 - c. Describe the proper clothing and other precautions for safely making observations at night and in cold weather.
 - d. Explain how to safely observe the Sun, objects near the Sun and solar eclipses.
2. Explain what light pollution is and how it and air pollution affect astronomy.
3. With the aid of diagrams (or real telescopes if available), do each of the following:
 - a. Explain why binoculars and telescopes are important astronomical tools. Demonstrate or explain how these tools are used.
 - b. Describe the similarities and differences of several types of astronomical telescopes, including at least one that observes light beyond the visible part of the spectrum (i.e., radio, X-ray, ultraviolet, or infrared).
 - c. Explain the purposes of at least three instruments used with astronomical telescopes.
 - d. Describe the proper care and storage of telescopes and binoculars both at home and in the field.



Astronomy Merit Badge Requirements

4. Do the following:
 - a. Identify in the sky at least 10 constellations, at least four of which are in the zodiac.
 - b. Identify in the sky at least eight conspicuous stars, five of which are of magnitude 1 or brighter.
 - c. Make two sketches of the Big Dipper. In one sketch, show the Big Dipper's orientation in the early evening sky. In another sketch, show its position several hours later. In both sketches, show the North Star and the horizon. Record the date and time each sketch was made.
 - d. Explain what we see when we look at the Milky Way.
5. Do the following:
 - a. List the names of the five most visible planets. Explain which ones can appear in phases similar to lunar phases and which ones cannot, and explain why.
 - b. Using the Internet (with your parent's permission), books, and other resources, find out when each of the five most visible planets that you identified in requirement 5a will be observable in the evening sky during the next 12 months, then compile this information in the form of a chart or table.
 - c. Describe the motion of the planets across the sky.
 - d. Observe a planet and describe what you saw.



Astronomy Merit Badge Requirements

6. Do the following:
 - a. Sketch the face of the Moon and indicate at least five seas and five craters. Label these landmarks.
 - b. Sketch the phase and the position of the Moon at the same hour and place, for four nights within a one week period. Include landmarks on the horizon such as hills, trees, and buildings. Explain the changes you observe.
 - c. List the factors that keep the Moon in orbit around Earth.
 - d. With the aid of diagrams, explain the relative positions of the Sun, Earth, and the Moon at the times of lunar and solar eclipses, and at the times of new, first-quarter, full, and last-quarter phases of the Moon.
7. Do the following:
 - a. Describe the composition of the Sun, its relationship to other stars, and some effects of its radiation on Earth's weather and communications.
 - b. Define sunspots and describe some of the effects they may have on solar radiation.
 - c. Identify at least one red star, one blue star, and one yellow star (other than the Sun). Explain the meaning of these colors.



Astronomy Merit Badge Requirements

8. With your counselor's approval and guidance, do ONE of the following:
 - a. Visit a planetarium or astronomical observatory. Submit a written report, a scrapbook, or a video presentation afterward to your counselor that includes the following information:
 1. Activities occurring there
 2. Exhibits and displays you saw
 3. Telescopes and instruments being used
 4. Celestial objects you observed.
 - b. Plan and participate in a three-hour observation session that includes using binoculars or a telescope. List the celestial objects you want to observe, and find each on a star chart or in a guidebook. Prepare a log or notebook. Discuss with your counselor what you hope to observe prior to your observation session. Review your log or notebook with your counselor afterward.**
 - c. Plan and host a star party for your Scout troop or other group such as your class at school. Use binoculars or a telescope to show and explain celestial objects to the group.
 - d. Help an astronomy club in your community hold a star party that is open to the public.
 - e. Personally take a series of photographs or digital images of the movement of the Moon, a planet, an asteroid, meteor, or a comet. In your visual display, label each image and include the date and time it was taken. Show all positions on a star chart or map. Show your display at school or at a troop meeting. Explain the changes you observed.



Astronomy Merit Badge Requirements

9. Find out about three career opportunities in astronomy. Pick one and find out the education, training, and experience required for this profession. Discuss this with your counselor, and explain why this profession might interest you.



Requirement 1



Do the following:

- a. Explain to your counselor the most likely hazards you may encounter while participating in astronomy activities, and what you should do to anticipate, help prevent, mitigate, and respond to these hazards.
- b. Explain first aid for injuries or illnesses such as heat and cold reactions, dehydration, bites and stings, and damage to your eyes that could occur during observation.
- c. Describe the proper clothing and other precautions for safely making observations at night and in cold weather.
- d. Explain how to safely observe the Sun, objects near the Sun and solar eclipses.

Hazards



- **Weather:** Dress appropriately for being outdoors for extended periods of time. Be prepared for changes in temperature when going from daytime to nighttime.
- **Insects and animal bites:** Use bug spray and cover exposed skin. Wear closed toed shoes.
- **Darkness:** Prepare your site during the daytime and note/mark any holes, crevices, or other tripping hazards. Use red-filtered flashlights.
- **Eye damage:** Never look directly at the Sun, even if you are wearing sunglasses. Never look at the Sun through binoculars or telescopes without proper lens.



Requirement 1



Do the following:

- a. Explain to your counselor the most likely hazards you may encounter while participating in astronomy activities, and what you should do to anticipate, help prevent, mitigate, and respond to these hazards.
- b. Explain first aid for injuries or illnesses such as heat and cold reactions, dehydration, bites and stings, and damage to your eyes that could occur during observation.
- c. Describe the proper clothing and other precautions for safely making observations at night and in cold weather.
- d. Explain how to safely observe the Sun, objects near the Sun and solar eclipses.

Sunburns



- Severe sunburn can be a significant first aid situation.
- Sunburn is preventable with protective ointments, clothing, or staying out of the sun.
- Long term effects of sunburn has been linked to skin cancers.

Sunburns



- Symptoms:
 - Redness.
 - Minor inflammation, or swelling.
 - Pain.
 - Dry, peeling skin occurs as the burn heals.
- Treatment:
 - Soak the wound in cool water for five minutes or longer.
 - Take acetaminophen or ibuprofen for pain relief.
 - Apply lidocaine (an anesthetic) with Aloe Vera to soothe the skin.
 - Use an antibiotic ointment and loose gauze to protect the affected area.
 - Make sure you don't use ice, as this may make the damage worse.

Dehydration

- When the body puts out more liquid than it is taking in.
- Ways we lose fluids:
 - Sweating.
 - Urination.
 - Vomiting.
- Signs of dehydration:
 - Thirst.
 - Yellow or dark urine.
 - Dry mouth.
 - Lightheadedness.
 - Nausea and vomiting.
 - Dry skin.
 - Cease sweating.

- Treatment:
 - Drink fluids (water, Gatorade).
 - Avoid physical activity.
 - Get inside air conditioned or cool area.



Heat Emergencies



HEAT EXHAUSTION

1. MOIST & CLAMMY SKIN
2. PUPILS DILATED
3. NORMAL OR SUBNORMAL TEMPERATURE

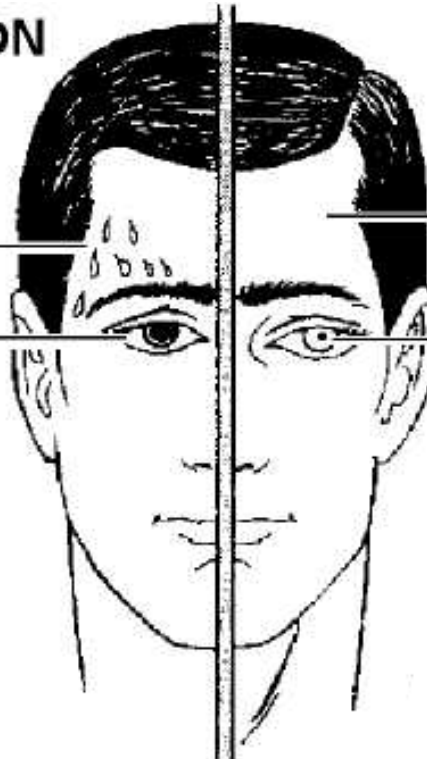

HEAT STROKE

1. DRY HOT SKIN
2. PUPILS CONSTRICTED
3. VERY HIGH BODY TEMPERATURE

Heat Exhaustion Symptoms

- Heavy sweating
- Thirst
- Fatigue
- Heat cramps
- Headache
- Dizziness
- Nausea
- Vomiting



First Aid for Heat Exhaustion

- Move victim from heat to rest in a cool place.
- Loosen or remove unnecessary clothing.
- Give water or a sports drink.
- Raise feet 8-12 inches.
- Put cool, wet cloths on forehead and body – spray skin with water.
- Seek medical care if victim's condition worsens or does not improve within 30 minutes.



HEAT EXHAUSTION

OR

HEAT STROKE

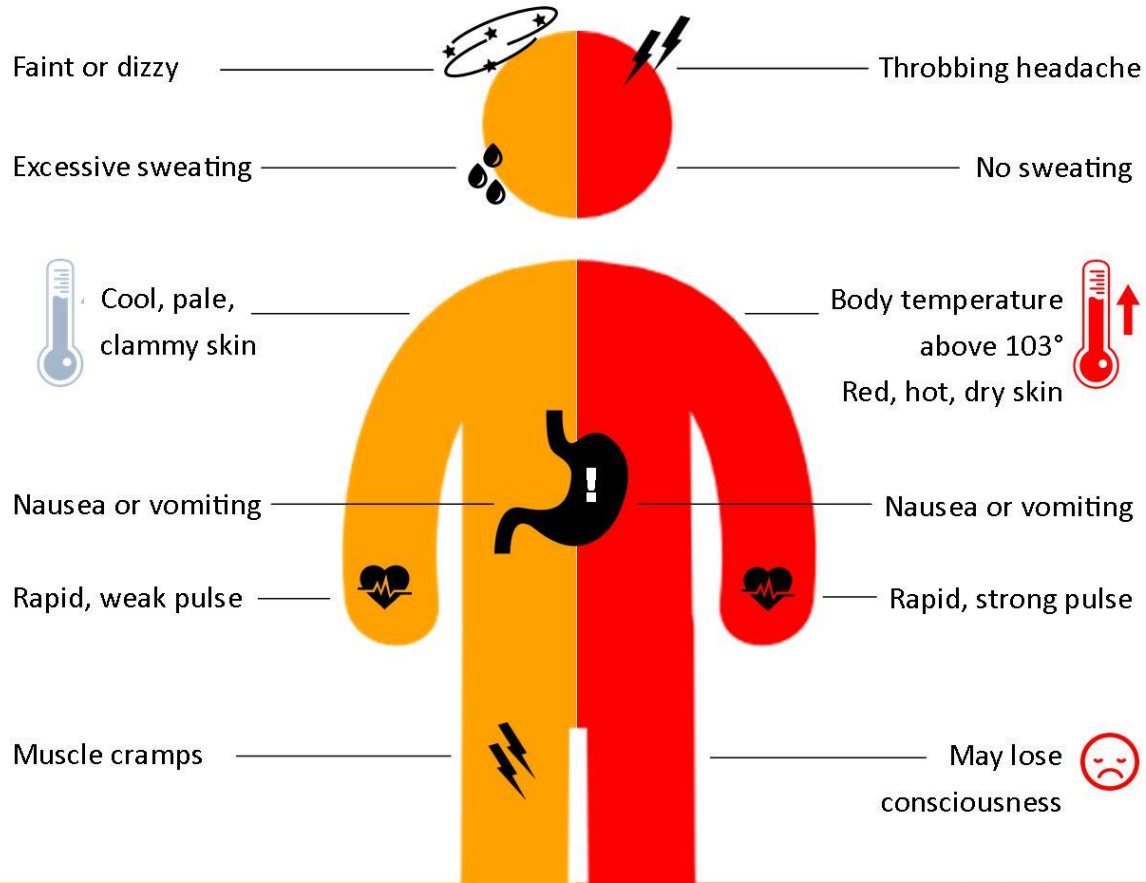

- Get to a cooler, air conditioned place
- Drink water if fully conscious
- Take a cool shower or use cold compresses

CALL 9-1-1

- Take immediate action to cool the person until help arrives

First Aid for Heat Stroke

- Call 911.
- Move victim to cool place.
- Remove outer clothing.
- Cool victim quickly.
- Apply cold compresses or spray skin with water.
- Put ice bags or cold packs beside neck, armpits, and groin.

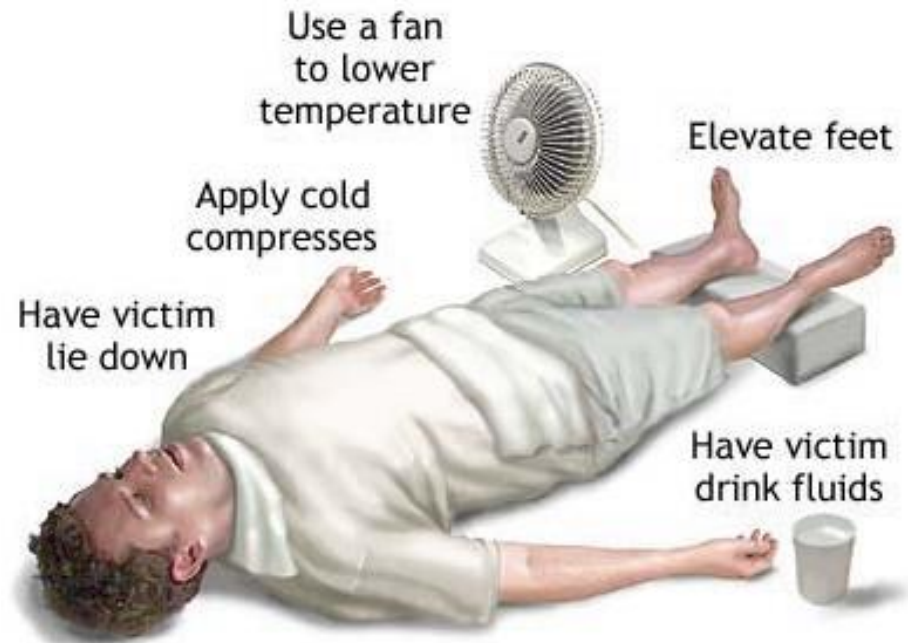

Hypothermia



- Occurs when body cannot make heat as fast as it loses it.
- Internal body temperature drops below 95°F.
- Can occur whenever and wherever a person feels cold, including indoors in poorly heated areas.

First Aid for Hypothermia

- Move victim to shelter.
- Remove wet clothing and victim in warm covers.
- Apply direct body heat.
- Re-warm neck, chest, abdomen, and groin first.
- Give warm, sweet drinks if conscious.
- Monitor breathing, administer CPR.
- Get medical help.



Insect Bites



- Bites of mosquitoes, chiggers (harvest mites), fleas, and bedbugs usually cause itchy, red bumps. The size of the swelling can vary from a dot to a half inch.
- Signs that a bite is from a mosquito are: itchiness, a central raised dot in the swelling, a bite on skin not covered by clothing, and summertime,
- Fleas and bedbugs tend to bite skin under clothing. Flea bites often turn into little blisters in young children.
- Bites from horseflies, deerflies, gnats, fire ants, harvester ants, blister beetles, and centipedes usually cause a painful, red bump. Fire ant bites change to blisters or pimples within a few hours.



Treatment of Insect Bites

- Apply calamine lotion or a baking soda paste to the area of the bite.
- If the itch is severe (as with chiggers), apply nonprescription 1% hydrocortisone cream four times a day.
- Do not to pick at the bites or they can become infected or leave scars.
- Cold, moist compresses or ice on the area can help.



Tick Bites

- Can transmit Rocky Mountain Spotted Fever or Lyme Disease.
- Tick embeds it's mouthparts in skin and may remain for days sucking blood.



Engorged Tick



Tick Removal

- Grasp the tick's mouthparts against the skin, using pointed tweezers.
- Pull steadily without twisting until you can ease the tick head straight out of the skin.
- DO NOT squeeze or crush the body of the tick.
- DO NOT apply substances such as petroleum jelly, nail polish, or a lighted match to the tick while it is attached.

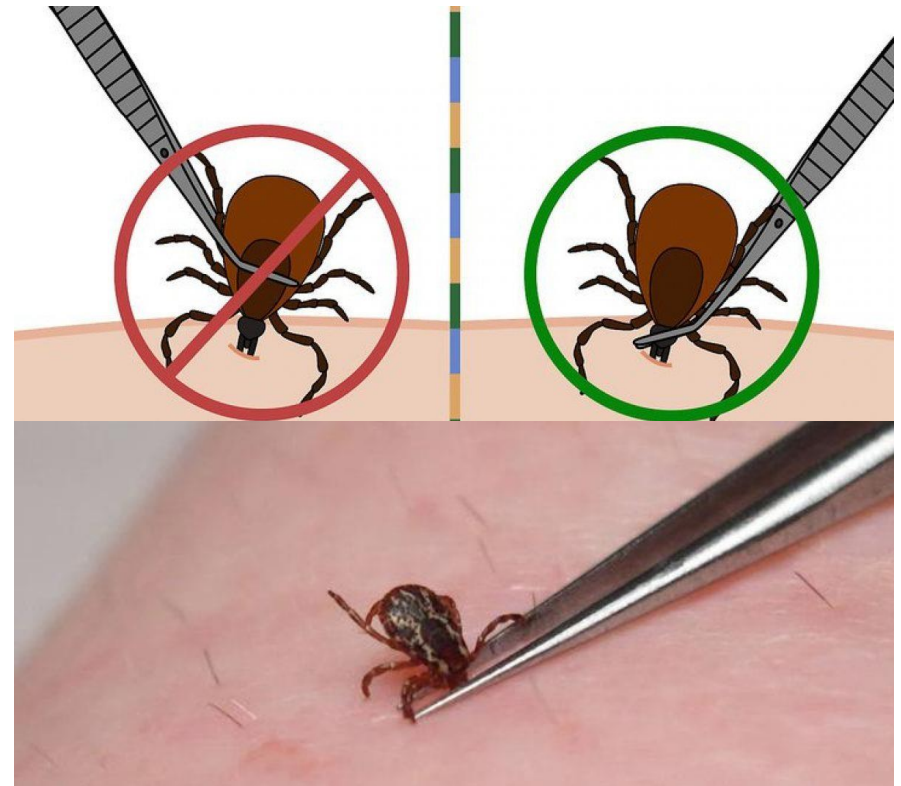

Tick Removal Cont.

- Once you have removed the tick, wash the wound site and your hands with soap and water, and apply rubbing alcohol or antiseptic to the site.
- Observe the bite over the next two weeks for any signs of an expanding red rash or flu-like symptoms (Lyme Disease).



Lyme Disease Rash

Bee Stings

- Honey bees, bumble bees, hornets, wasps, and yellow jackets can all sting.
- These stings cause immediate painful red bumps.
- While the pain is usually better in 2 hours, the swelling may increase for up to 24 hours.



Treatment of stings

- If you see a little black dot in the bite, the stinger is still present (this only occurs with honey bee stings).
- Remove it by scraping it off with a credit card or something similar.
- For persistent pain, massage with an ice cube for 10 minutes.
- Give acetaminophen immediately for relief of pain and burning.
- For itching, apply hydrocortisone cream.

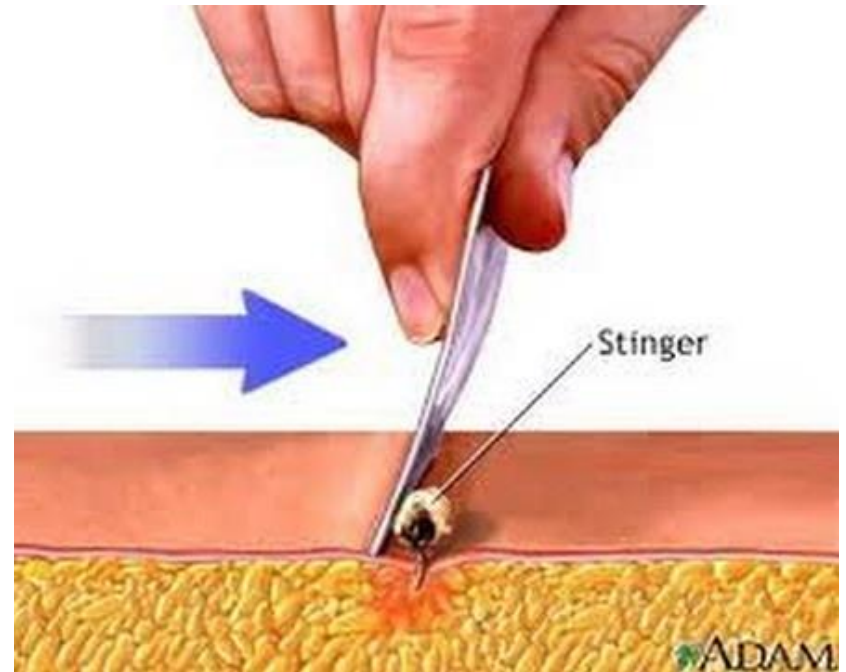

Sun Damage to Eyes



- The UV rays of the sun can damage your eyes.
- If you are in the Sun and you or a companion experience eye discomfort, cover the eyes and seek medical attention immediately.
- If your eyes have been overexposed to the sun, you can develop ultraviolet keratitis (sunburn of the cornea), with symptoms generally lasting from 6 to 24 hours, although they can last as long as 48 hours.
- Symptoms of ultraviolet keratitis include the following:
 - Discomfort or redness in the eyes
 - Tears
 - Blurry vision
 - Swelling
 - Light sensitivity
 - Eyelid twitching
 - Gritty feeling in the eyes
 - Short-term loss of vision
 - Seeing halos



Sun Damage to Eyes

- Avoiding sun damage to your eyes in the first place is the best way to prevent serious issues.
- Wearing a hat and sunglasses when going out in the day, especially if you will be outside for a long time, is the best solution to avoiding eye damage.
- Remember that clouds are not an excuse to stare in the direction of the sun. Clouds do not block enough of the sun's rays to mitigate harm.





Requirement 1



Do the following:

- a. Explain to your counselor the most likely hazards you may encounter while participating in astronomy activities, and what you should do to anticipate, help prevent, mitigate, and respond to these hazards.
- b. Explain first aid for injuries or illnesses such as heat and cold reactions, dehydration, bites and stings, and damage to your eyes that could occur during observation.
- c. **Describe the proper clothing and other precautions for safely making observations at night and in cold weather.**
- d. Explain how to safely observe the Sun, objects near the Sun and solar eclipses.

Proper Clothing

- When you go stargazing, dress appropriately for the weather—hot or cold.
- Sun exposure can catch you by surprise when you are outside, preoccupied with setting up your equipment or viewing a solar eclipse. Wear loose-fitting clothing that completely covers the arms and legs, and a brimmed hat.
- In cold weather, wear layers to keep in the heat. Bring along a woolen cap, scarf, gloves, extra socks, and a coat. Keep your arms and legs covered.
- Wear shoes or boots—not sandals—and socks.
- Always carry rain gear.





Requirement 1



Do the following:

- a. Explain to your counselor the most likely hazards you may encounter while participating in astronomy activities, and what you should do to anticipate, help prevent, mitigate, and respond to these hazards.
- b. Explain first aid for injuries or illnesses such as heat and cold reactions, dehydration, bites and stings, and damage to your eyes that could occur during observation.
- c. Describe the proper clothing and other precautions for safely making observations at night and in cold weather.
- d. Explain how to safely observe the Sun, objects near the Sun and solar eclipses.

Safely Observe the Sun



- Do not **look** directly at the sun.
- Do not use homemade filters or ordinary sunglasses, even very dark sunglasses.
- Use special-purpose **solar** filters, such as **eclipse** glasses or handheld **solar** viewers, to **view** the **eclipse**.
- Read and follow filter instructions and supervise children.



Safe Observations



- An alternative method for safe viewing of the partially eclipsed Sun is indirectly via pinhole projection.
- Pass sunlight through a small opening (a hole punched in an index card) and project an image of the Sun onto a nearby surface (another card or a sheet of paper).

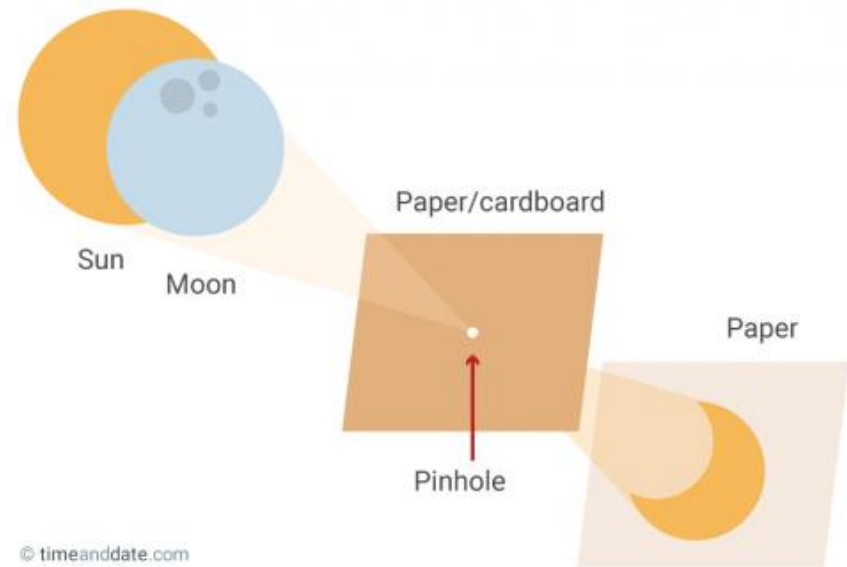

Safe Observations

- **Objects near the sun:** Look for Mercury only when the sun is below the horizon. Mercury is visible only in bright twilight and is either very low in the western sky after sunset or very low in the east before sunrise.
- **Moon:** The Moon at new-moon phase also lies in the direction of the Sun. The new Moon is in the sky all day, but it is not visible in the Sun's glare. Do not look at or near the Sun while trying to view a new moon. Wait a couple of days after the new moon, then look for a thin crescent moon in the evening sky just after sunset.





Requirement 2



2. Explain what light pollution is and how it and air pollution affect astronomy.



Light Pollution

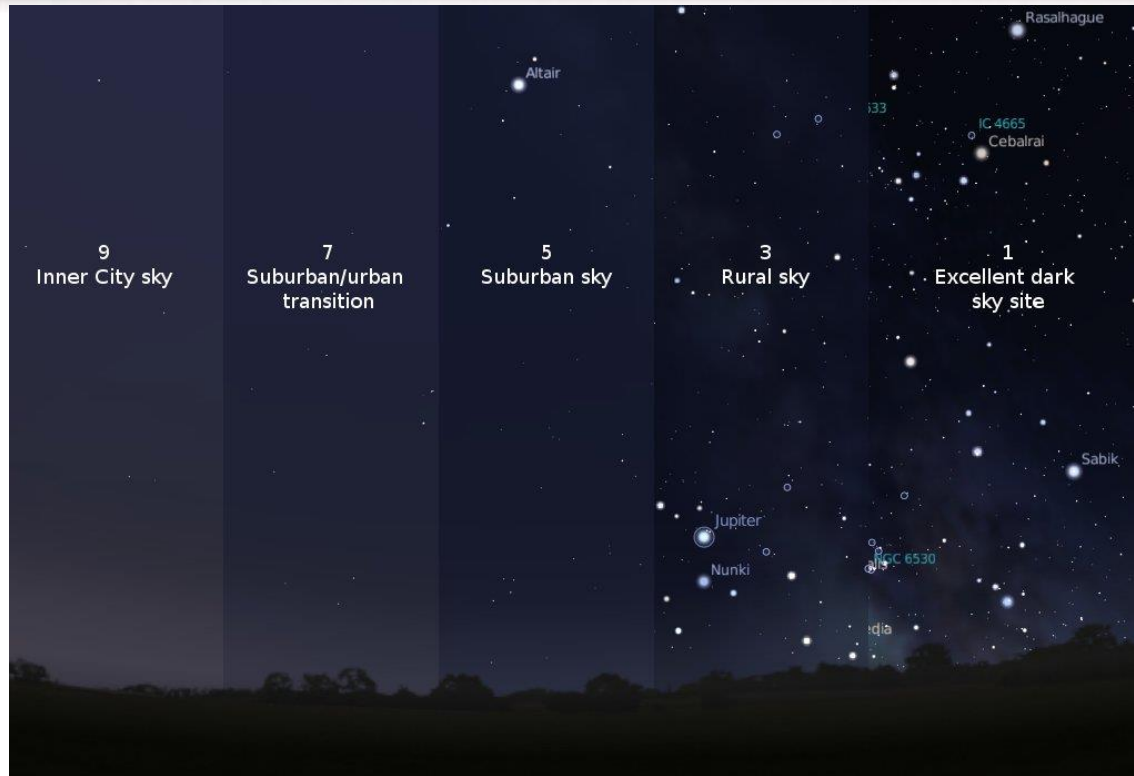

- Light pollution is artificial light introduced into the natural night, especially where it is not needed or wanted.
- This unwanted light appears in the sky, causing sky glow, obscuring the stars and creating perpetual twilight.

Other Viewing Limitations

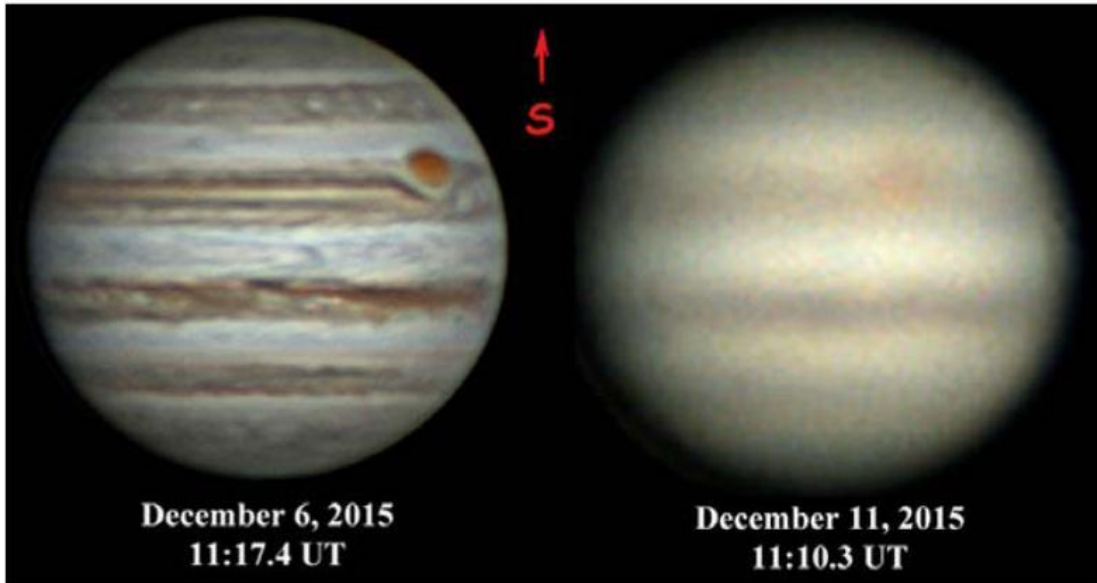

Figure 2. Jupiter, captured with the same equipment in good (left) and bad (right) seeing conditions. *Cliff Ashcraft, New Jersey, USA*

- **Air Pollution:** In the US, pollutants from power plants and vehicle exhausts are the primary cause of haze in the Eastern US.
- **Natural Conditions:** Air turbulence, humidity, and clouds can also interfere with your ability to view the night sky unencumbered.



Requirement 3



With the aid of diagrams (or real telescopes if available), do each of the following:

- a. Explain why binoculars and telescopes are important astronomical tools. Demonstrate or explain how these tools are used.
- b. Describe the similarities and differences of several types of astronomical telescopes, including at least one that observes light beyond the visible part of the spectrum (i.e., radio, X-ray, ultraviolet, or infrared).
- c. Explain the purposes of at least three instruments used with astronomical telescopes.
- d. Describe the proper care and storage of telescopes and binoculars both at home and in the field.

Tools of the Trade

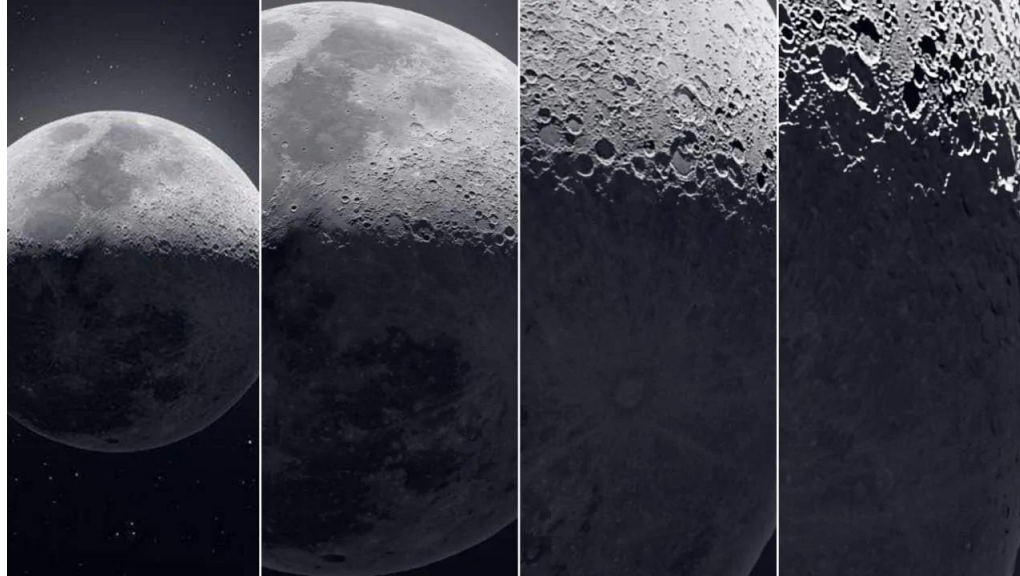

- You can observe objects in the night sky with your unaided eye.
- However, with binoculars or a telescope, the images you see will appear brighter and larger.
- They collect more light than the human eye, so you can see more stars.
- They also improve the clarity and intensify the colors of the stars you see.

Advantages of Binoculars

- Binoculars allow you to use both eyes to view.
- Binoculars show the image the right way up (as opposed to telescopes that show the image upside down).
- Binoculars are easier to transport and can be handheld.
- Binoculars are often cheaper than telescopes.



How to Use Binoculars



- Read the manual and take whatever time is needed to learn its use and operation.
- To get the clearest images out of your binoculars, you'll need to adjust them to your eyes. To do this, find a sign or another object that doesn't move, and stand about 30 ft. away from it. Then follow these steps:
 1. Adjust the Eye Cups - Most binoculars have adjustable *eye cups* on each eyepiece. These eye cups should be **DOWN** if you wear glasses, **UP** if you do not.
 2. Adjust the Width - Binoculars have two eyepieces connected by a *center hinge*. The eyepieces can move in and out to change how far apart they are. You want to set your eyepieces to match your eyes. To do this, first spread the eyepieces as far apart as they will go, then put the binoculars up to your eyes. Move the eyepieces together until you see the two circles in your view merge into one.
 3. Set the Focus - All binoculars have a *focus wheel*, usually in the middle, which changes the focus of both eyepieces at once. You can use this wheel to focus your binoculars every time you look at an object.

How to Use Binoculars (continued)



- In addition to the focus wheel, most binoculars also have a ***dioptric ring***, which is a smaller adjustment wheel that adjusts a single eyepiece (usually the right one). Often the diopter is found on the eyepiece itself. The diopter allows you to set the binoculars for your particular eyes, and you need to set it only once.
- Turn both the diopter and the focus wheel counter-clockwise until they stop. Now, cover the right eyepiece (or the one with the diopter adjustment ring). Looking through the left eyepiece with your left eye, turn the focus wheel until the sign comes into focus. Get it as sharp as you can.
- Next, cover the left eyepiece and look at the sign using only the right eyepiece. The sign will probably be a tiny bit blurry, so turn the diopter adjustment ring until it comes into focus.
- There! You've adjusted your binoculars for the difference between your two eyes. From now on, to focus something, you'll only need to turn the **focus wheel**.

How to Use a Telescope



- **Read the manual** and take whatever time is needed to learn its use and operation. Be sure that you have assembled everything with great care. In the beginning, practice how to aim and focus your new instrument, not on the night sky, but on daytime terrestrial objects. Not only are these daytime targets bright and easy to see, but unlike night sky objects, they will not drift out of your field of view because of the rotation of the Earth.
- **Learn how to use the optical finder** (The small telescope that is held onto the top of the main telescope with a finder bracket.) Finders are an important telescope accessory, because they literally do what their name implies, help you find things! Without a finder on your telescope, you will spend most of your time trying to find objects instead of looking at them. When you look through the eyepiece, you will see a crosshair to help you center the object in the finder's field of view.
- **Use Your Lowest Power Eyepiece Whenever You Start Observing.** It is way easier to find and center an object if you are searching for it in a wider swath of sky. The more magnification you use, the less celestial real estate you will see, and the more precise you will have to be to get your target into the field of the eyepiece.
- **Remember to Focus:** You should focus the image so that it looks as sharp as possible.



Requirement 3



With the aid of diagrams (or real telescopes if available), do each of the following:

- a. Explain why binoculars and telescopes are important astronomical tools. Demonstrate or explain how these tools are used.
- b. Describe the similarities and differences of several types of astronomical telescopes, including at least one that observes light beyond the visible part of the spectrum (i.e., radio, X-ray, ultraviolet, or infrared).**
- c. Explain the purposes of at least three instruments used with astronomical telescopes.
- d. Describe the proper care and storage of telescopes and binoculars both at home and in the field.

Refracting Telescopes

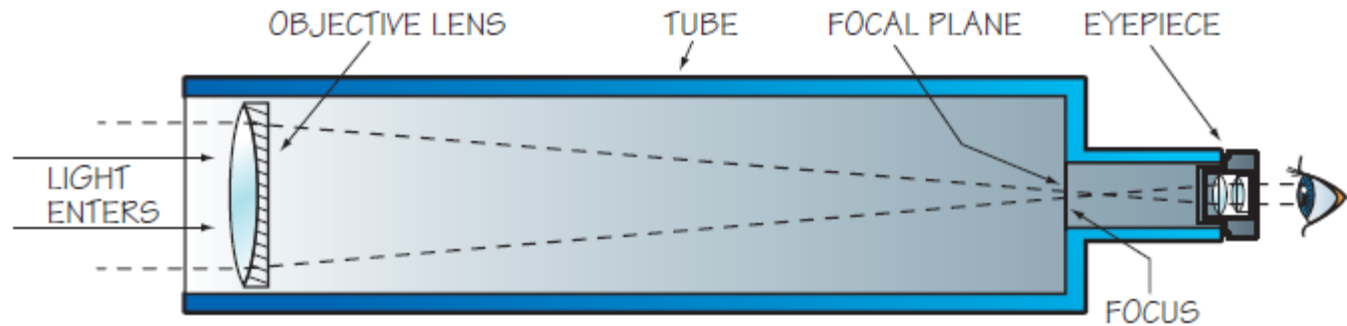

- **Refracting telescopes:** Use a system of **lenses** to collect and focus the incoming light.
- These are the earliest type of telescopes, first patented by Galileo Galilei in 1609.
- Refracting telescopes are generally better for bright objects like the Moon.

Reflecting Telescopes

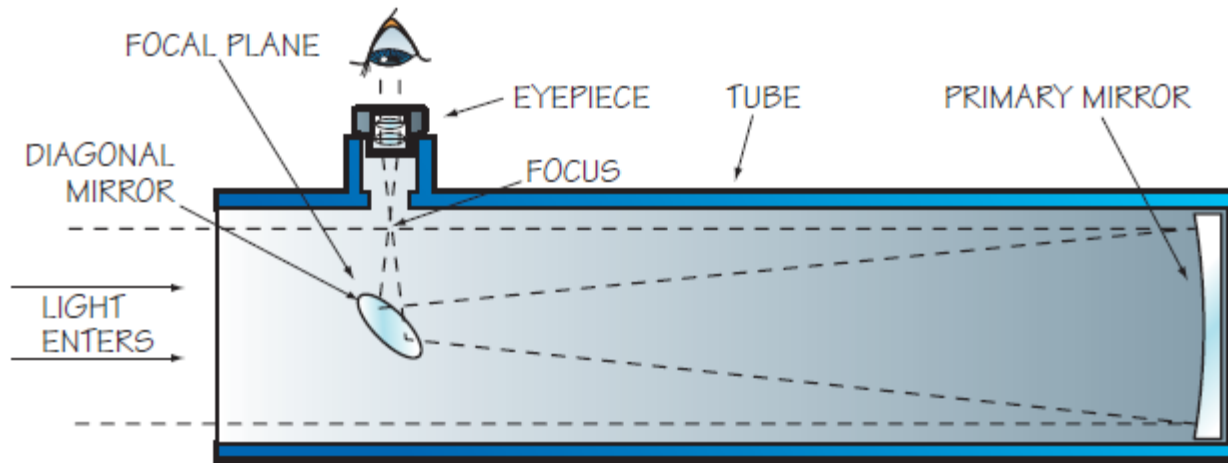

- **Reflecting telescopes:** Use a system of **mirrors** to concentrate incoming light.
- The first reflecting telescope was invented by Isaac Newton in 1668.
- Reflecting telescopes are better suited for deep-sky objects like star clusters and nebulas.

Catadioptric Telescope

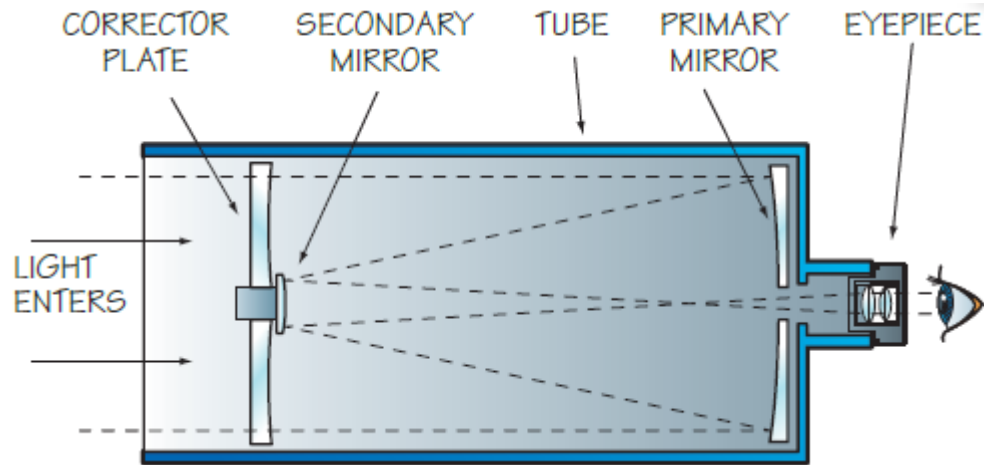

- The catadioptric telescope, also called a refracting-reflecting telescope, combines a large front lens with two mirrors.
- It has a short, enclosed tube and is often portable.

Radio Telescopes

- Radio telescopes pick up images that astronomers would not be able to see otherwise.
- Radio waves from space enter the telescope's large bowl-shaped (dish) antenna, and the radio receiver picks up the signals.
- A computer converts the signals into images.
- Radio signals reveal details, including temperature and composition, of objects in space that give off radio waves.



X-Ray Telescopes



- X-ray telescopes help scientists determine the galaxy's hot spots.
- X-rays from distant galaxies are absorbed by Earth's atmosphere, making them impossible to study from the ground.
- Cosmic X-rays—the invisible radiation emitted from very hot help scientists study dying stars, colliding galaxies, and quasars, extremely bright starlike objects that give off enormous amounts of energy.

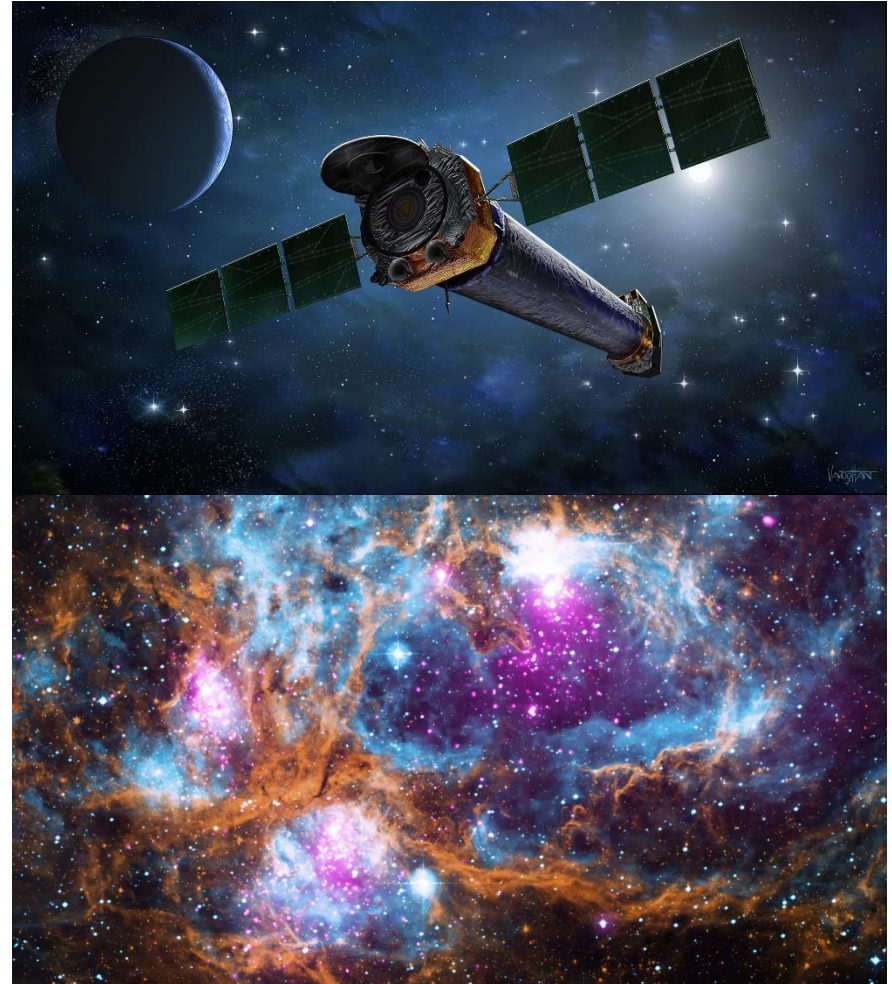

Multiwavelength Astronomy



CRAB NEBULA

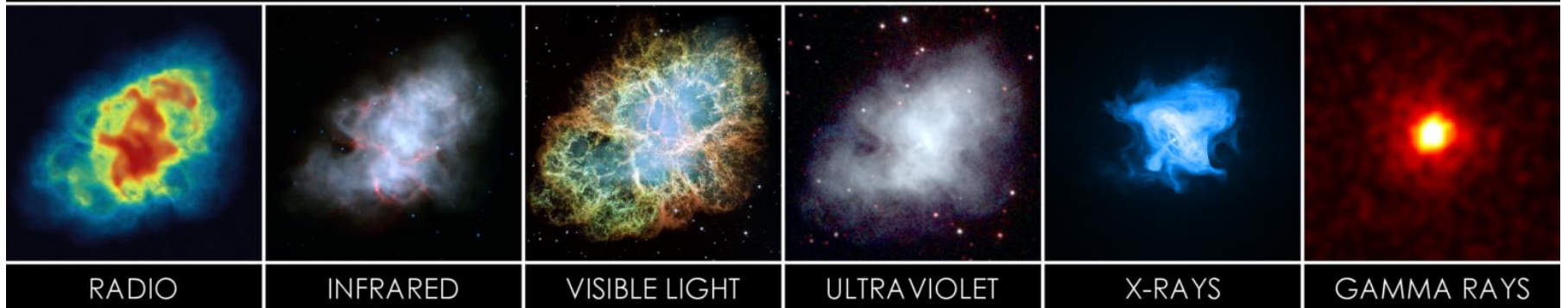



Requirement 3



With the aid of diagrams (or real telescopes if available), do each of the following:

- a. Explain why binoculars and telescopes are important astronomical tools. Demonstrate or explain how these tools are used.
- b. Describe the similarities and differences of several types of astronomical telescopes, including at least one that observes light beyond the visible part of the spectrum (i.e., radio, X-ray, ultraviolet, or infrared).
- c. Explain the purposes of at least three instruments used with astronomical telescopes.**
- d. Describe the proper care and storage of telescopes and binoculars both at home and in the field.

Instruments Used with Telescopes

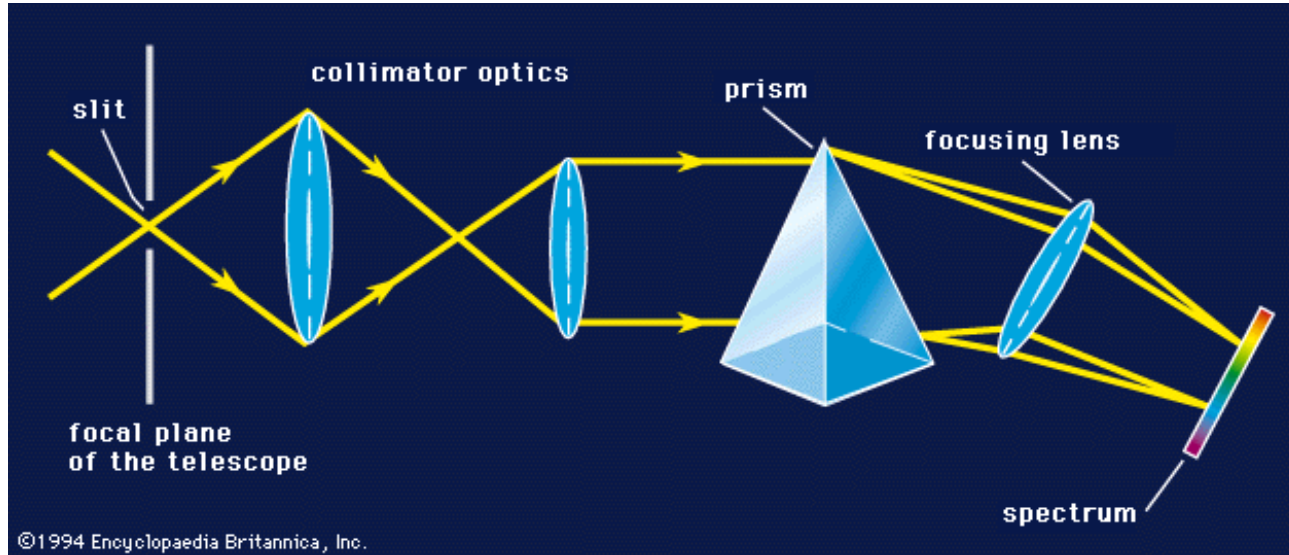

- **Spectrograph:** An instrument that separates light coming from a star into a pattern of colored lines (or spectrum).
- The more these lines are shifted to the red end of the spectrum, the farther away the star is from us.
- This is how we find the distance to stars in our part of the galaxy.

Instruments Used with Telescopes



- **Filar Micrometer:** Identifies the distance between two objects that are very close together.

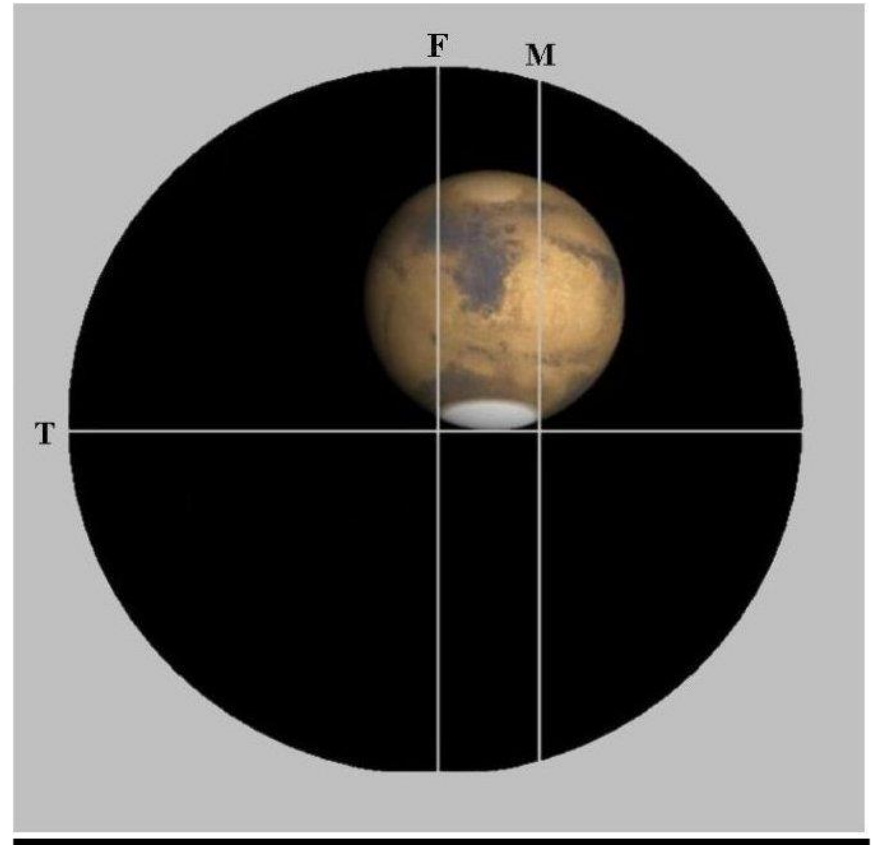

Instruments Used with Telescopes



- **Photometer:** Measures the brightness (luminosity) of a star; that is, the magnitude.
- By knowing the magnitude and the distance, astronomers can determine the size of the star, which helps identify their age.
- Photometers are also used to discover exoplanets (planets orbiting other stars).

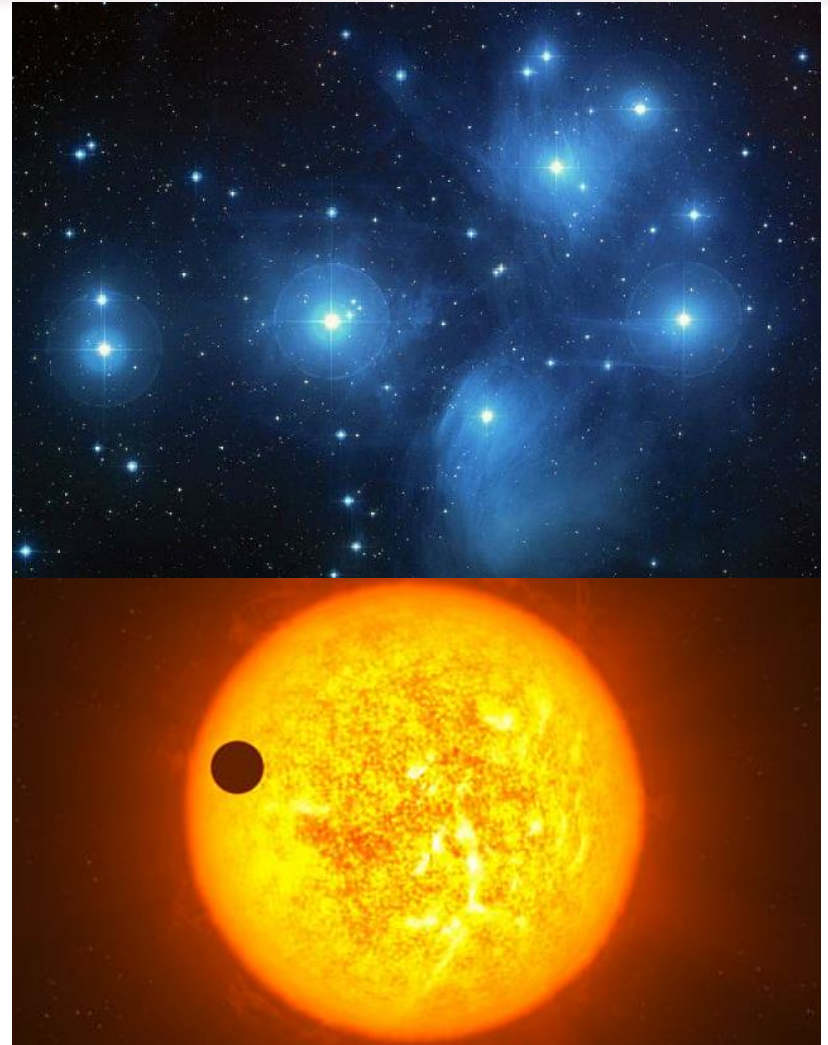



Requirement 3



With the aid of diagrams (or real telescopes if available), do each of the following:

- a. Explain why binoculars and telescopes are important astronomical tools. Demonstrate or explain how these tools are used.
- b. Describe the similarities and differences of several types of astronomical telescopes, including at least one that observes light beyond the visible part of the spectrum (i.e., radio, X-ray, ultraviolet, or infrared).
- c. Explain the purposes of at least three instruments used with astronomical telescopes.
- d. Describe the proper care and storage of telescopes and binoculars both at home and in the field.

Care of Binoculars and Telescopes



- Handle carefully and with respect. Try not to bump, shake or drop the instruments.
- Keep the equipment clean. Use a microfiber cloth with cleaner specifically made for lenses to clean. Apply cleaner to the cloth, not directly to the lens.
- Keep dust off lenses. Keep them covered with lens caps.
- Protect the equipment from water, especially saltwater.
- Use and wear the strap that comes with binoculars.
- Store instruments in a cool, dry place away from humidity and extreme temperatures.





Requirement 4



Do the following:*

- a. Identify in the sky at least 10 constellations, at least four of which are in the zodiac.
- b. Identify in the sky at least eight conspicuous stars, five of which are of magnitude 1 or brighter.
- c. Make two sketches of the Big Dipper. In one sketch, show the Big Dipper's orientation in the early evening sky. In another sketch, show its position several hours later. In both sketches, show the North Star and the horizon. Record the date and time each sketch was made.
- d. Explain what we see when we look at the Milky Way.

Constellations



- Constellations are groups of visible stars that form a perceived outline or pattern, typically representing an animal, mythological being, or object.
- In 1922, the International Astronomical Union (IAU) codified the modern sky map and adopted official constellation boundaries.
- There are 88 official constellations in the sky.

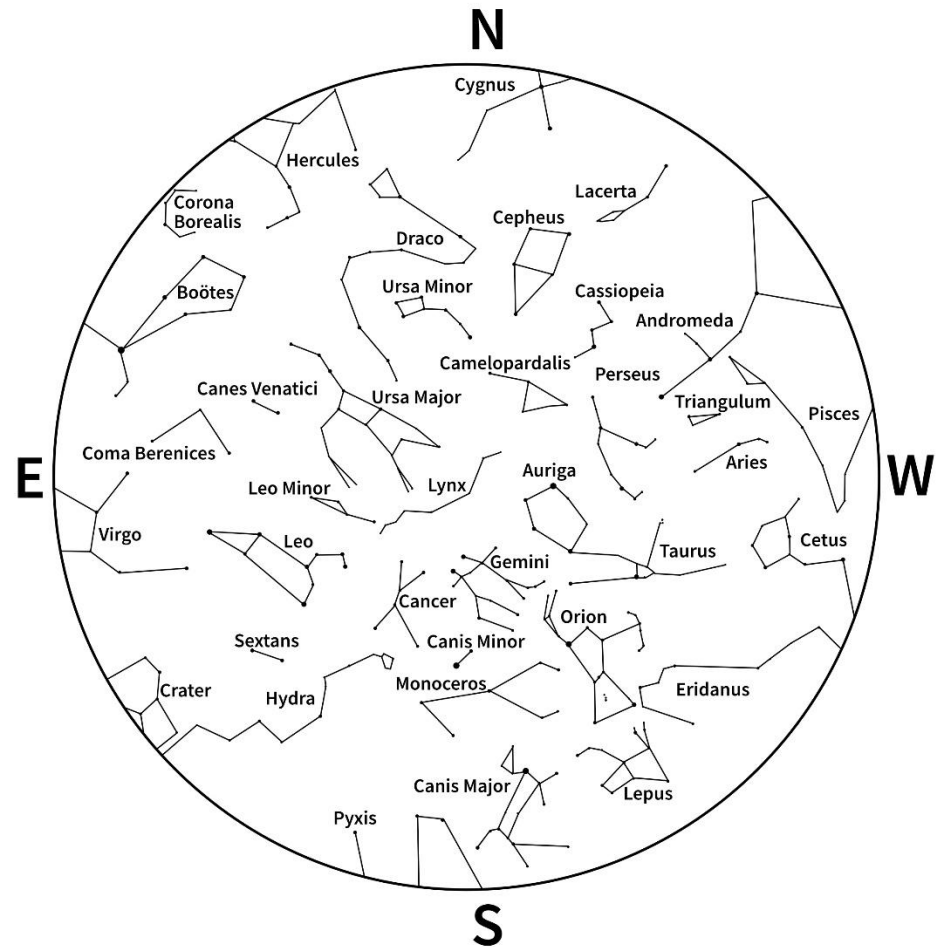

Asterisms

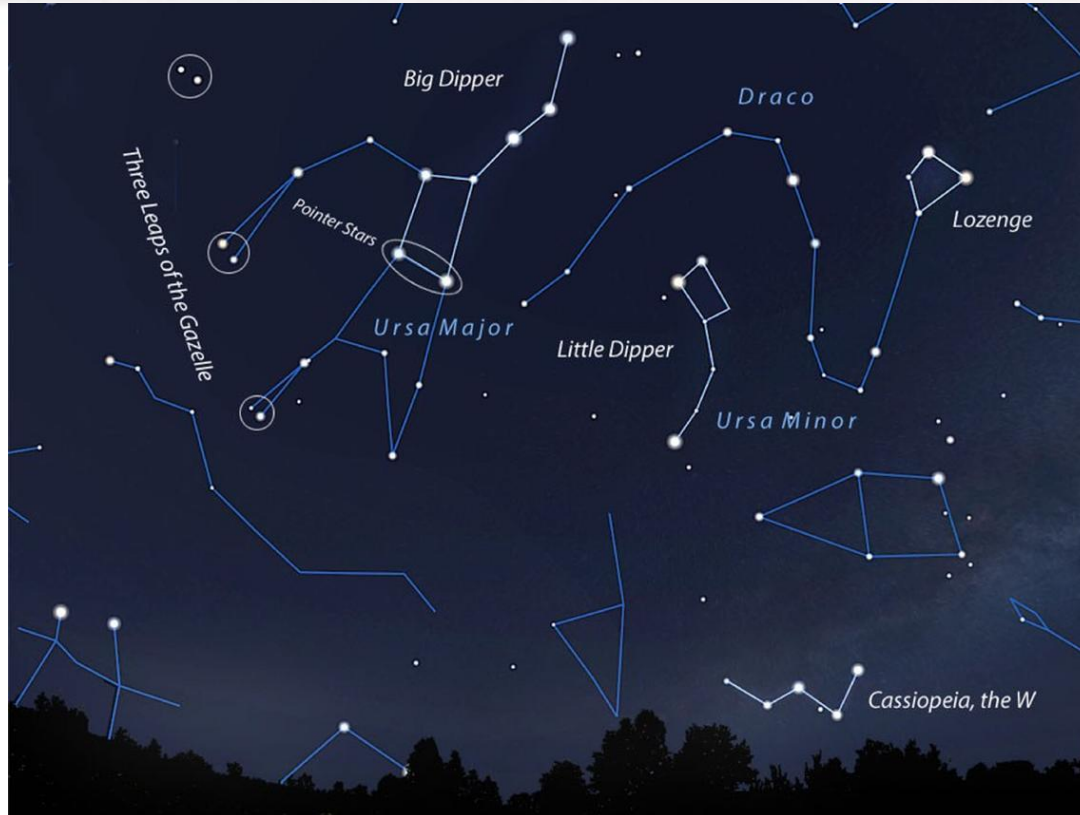

- Asterisms are other star patterns that are used by observers.
- One asterism is the Big Dipper, which is a small section of Ursa Major.

Circumpolar Constellations



- Due to the Earth's rotation and axial tilt, there are constellations that never appear to rise or set. These are called **circumpolar constellations**.
- In the Northern Hemisphere (where we live), these stars cluster around the star Polaris. Polaris is sometimes called the North Star or the Pole Star.
- Northern circumpolar constellations include Ursa Major, Ursa Minor, Draco, Cepheus, Cassiopeia, and Camelopardalis. These constellations are visible at most times of the year.

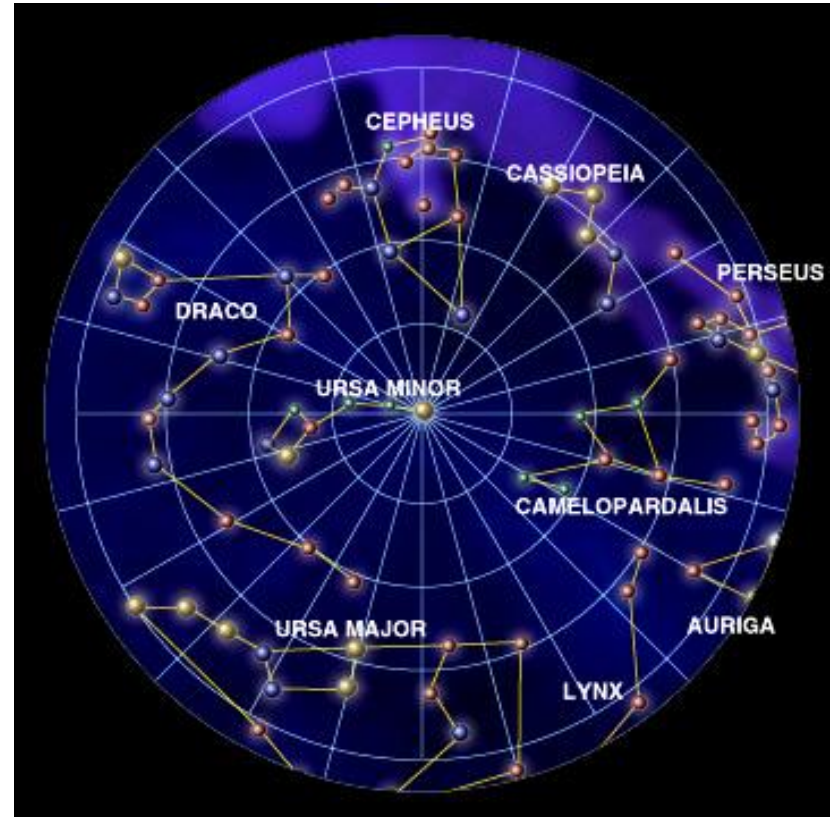

Zodiac Constellations

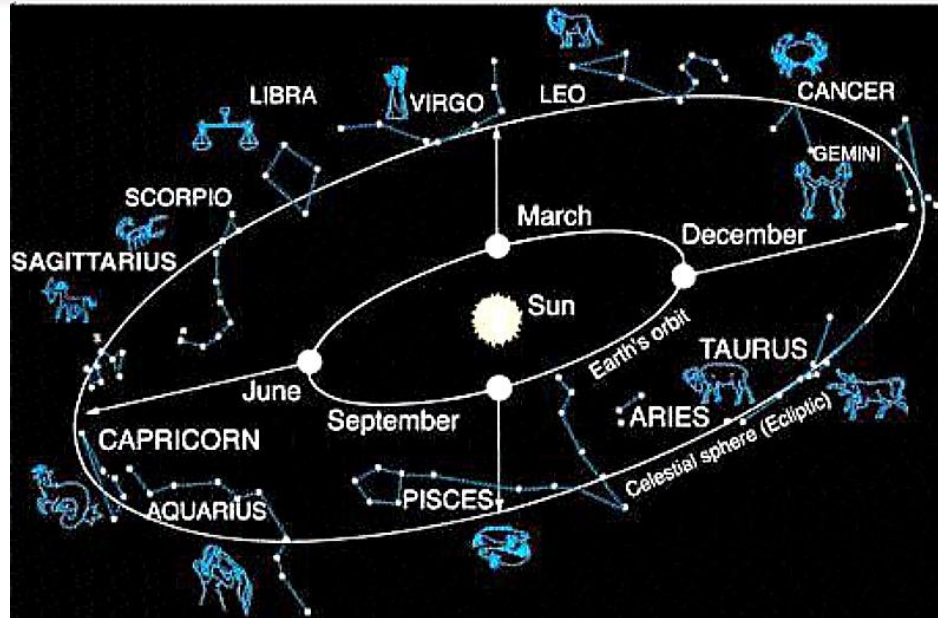

- There is a singular path that the Sun, Moon, and planets appear follow through the sky called the ecliptic.
- The 12 zodiac constellations map the ecliptic. You can see them in the evening sky during different seasons.
- Astrology is the belief that the zodiac constellation that was rising at the time when you were born somehow influences your personality.



Requirement 4



Do the following:*

- a. Identify in the sky at least 10 constellations, at least four of which are in the zodiac.
- b. Identify in the sky at least eight conspicuous stars, five of which are of magnitude 1 or brighter.
- c. Make two sketches of the Big Dipper. In one sketch, show the Big Dipper's orientation in the early evening sky. In another sketch, show its position several hours later. In both sketches, show the North Star and the horizon. Record the date and time each sketch was made.
- d. Explain what we see when we look at the Milky Way.

Conspicuous Stars



- A conspicuous star is a bright star that is easily seen with the naked eye.
- A star's magnitude is a measure of how bright it is.
- **Absolute magnitude** is the star's true brightness if all stars were viewed from the same distance.
- **Apparent magnitude** is the brightness of a star from Earth.
 - The lower the apparent magnitude number, the brighter the star.
 - Stars brighter than a magnitude of 1 have a zero or negative number.
- Listed here are some of the brightest stars in the sky, the constellations where they are found, and their apparent magnitude.

Star	Constellation	Magnitude
Sirius	Canis Major	-1.46
Arcturus	Boötes	-0.04
Vega	Lyra	0.03
Capella	Auriga	0.08
Rigel	Orion	0.12
Procyon	Canis Minor	0.38
Betelgeuse	Orion	0.5
Altair	Aquila	0.77
Aldebaran	Taurus	0.85
Antares	Scorpius	0.96
Spica	Virgo	0.98
Pollux	Gemini	1.14
Deneb	Cygnus	1.25

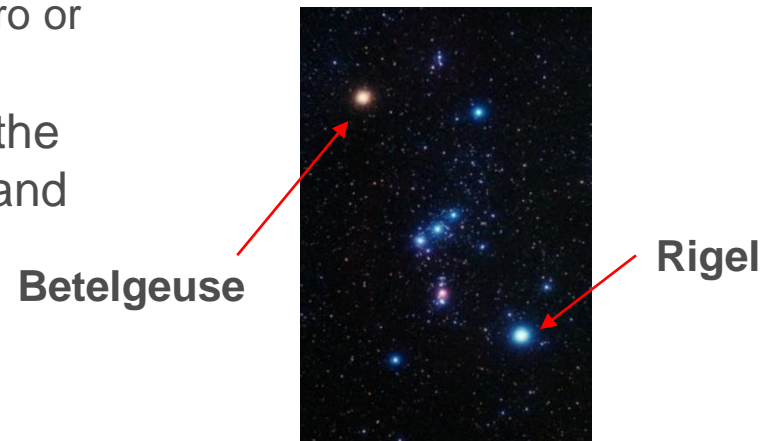



Requirement 4



Do the following:*

- a. Identify in the sky at least 10 constellations, at least four of which are in the zodiac.
- b. Identify in the sky at least eight conspicuous stars, five of which are of magnitude 1 or brighter.
- c. **Make two sketches of the Big Dipper. In one sketch, show the Big Dipper's orientation in the early evening sky. In another sketch, show its position several hours later. In both sketches, show the North Star and the horizon. Record the date and time each sketch was made.**
- d. Explain what we see when we look at the Milky Way.

Big Dipper and North Star

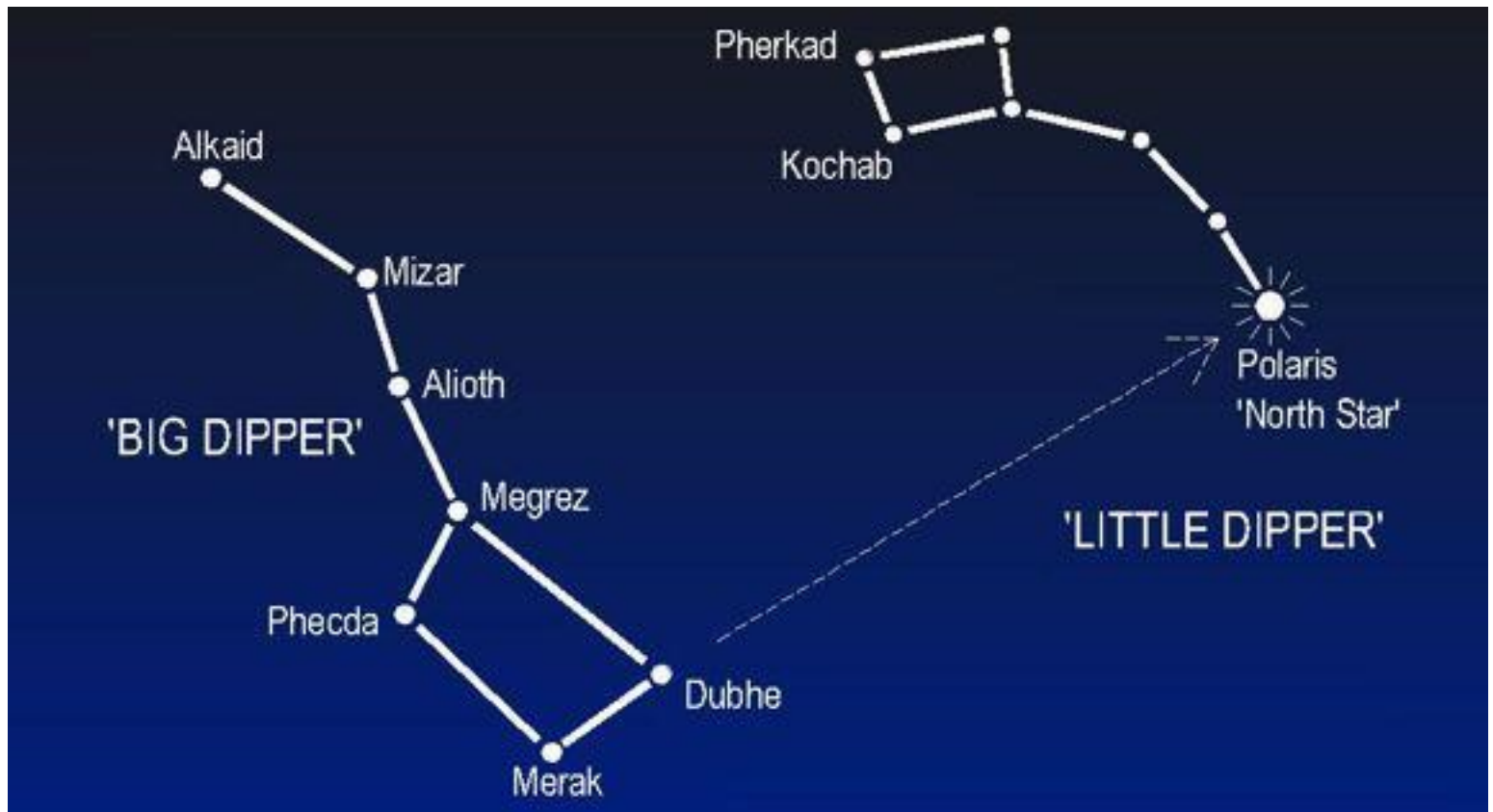

Movement of Constellations

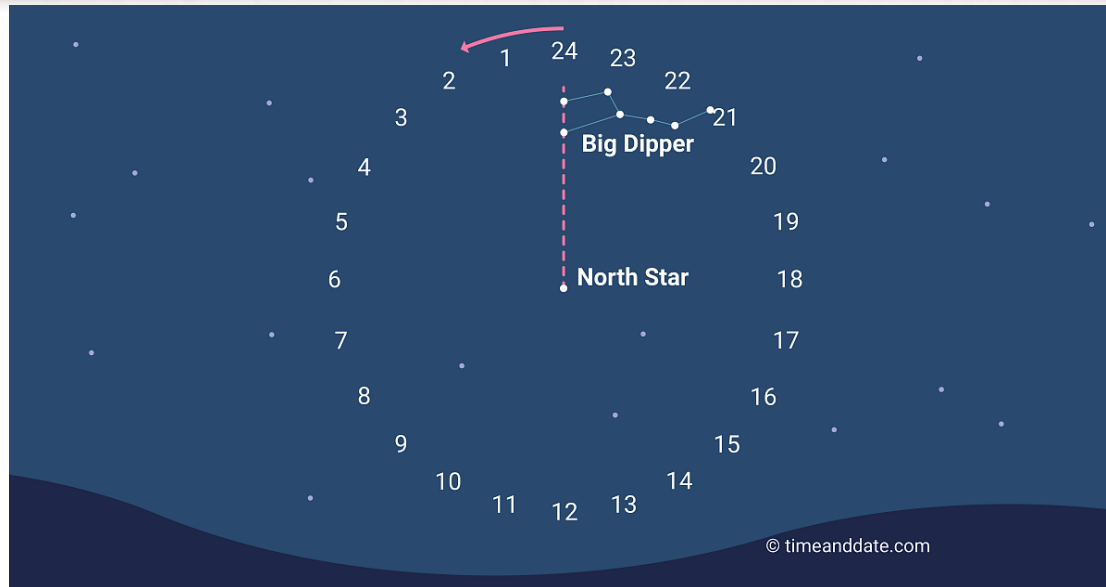

- The Earth moves in a counterclockwise spin (from west to east), so it makes the sky appear to rotate in the opposite direction, from east to west.
- The east-west path that the Sun, planets, and the Moon follow is called the ecliptic.
- If you watch the night sky for a few hours, you will see that the stars appear to rotate about a fixed point in the **sky** (which happens to be near the pole star, Polaris).



Requirement 4



Do the following:*

- a. Identify in the sky at least 10 constellations, at least four of which are in the zodiac.
- b. Identify in the sky at least eight conspicuous stars, five of which are of magnitude 1 or brighter.
- c. Make two sketches of the Big Dipper. In one sketch, show the Big Dipper's orientation in the early evening sky. In another sketch, show its position several hours later. In both sketches, show the North Star and the horizon. Record the date and time each sketch was made.
- d. Explain what we see when we look at the Milky Way.

The Milky Way



- Our solar system is part of a spiral galaxy called the Milky Way.
- Our galaxy's vast rotating disk of stars spans at least 170,000 light-years, and possibly up to 200,000 light-years.
- When we look up and see the Milky Way in the sky, we are looking edge-on at our galaxy.
- You are located about 2/3rds of the way from the center, closer to the edge.



Requirement 5



Do the following:

- a. List the names of the five most visible planets. Explain which ones can appear in phases similar to lunar phases and which ones cannot, and explain why.
- b. Using the Internet (with your parent's permission), books, and other resources, find out when each of the five most visible planets that you identified in requirement 5a will be observable in the evening sky during the next 12 months, then compile this information in the form of a chart or table.
- c. Describe the motion of the planets across the sky.
- d. Observe a planet and describe what you saw.

Planets

- Mercury, Venus, Mars, Jupiter, and Saturn were indentified by ancient Babylonian astronomers.
- Records can be found dating back to 1000 BCE.

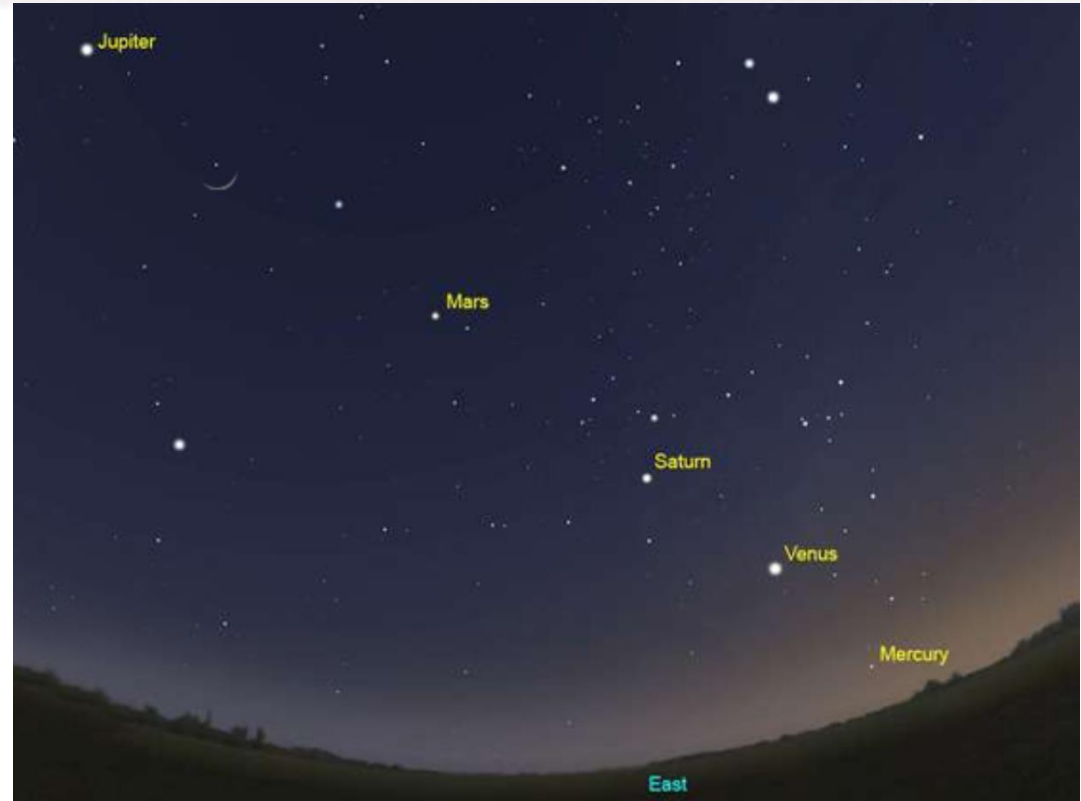

Planets



- The 'inferior' planets – so called because they are inside of Earth's orbit – appear to have phases like our Moon.
- It is easy to see these phases on Venus with binoculars.
- You will need a telescope to see the phases of Mercury, but wait until the Sun has set or look before it has risen.



Planets

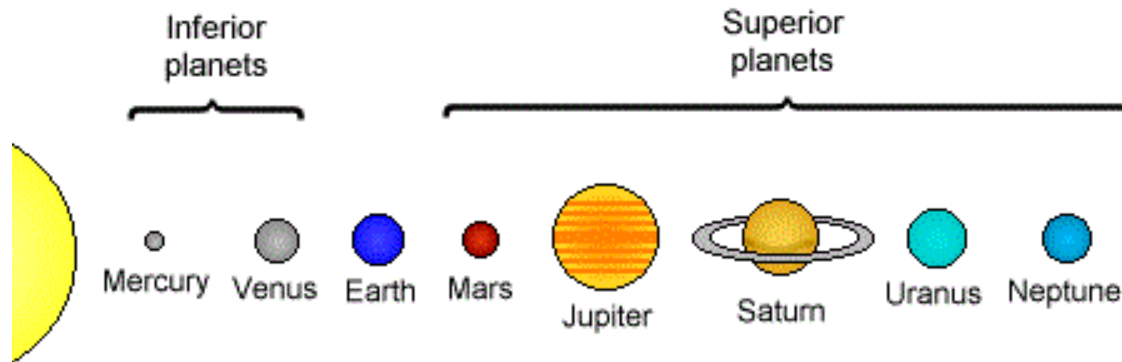

Sizes and distances not to scale.

- The 'superior' planets, Mars, Jupiter, and Saturn, are outside of Earth's orbit.
- This means that we always get the same view of the planet as the Sun, and therefore cannot see the part of the planet where the sun doesn't shine.
- Therefore, we are unable to see the phases.

Mercury



- Seeing Mercury with a telescope is a big challenge!
- While it occupies a place in the list of planets that can be seen with unaided eyes, spotting it can get quite difficult because Mercury is so close to the sun.
- Mercury races around the sun every 88 days, which means we get several short viewing windows every year.
- The downside of being so close to the sun is that it is never visible in a truly dark sky – only dawn and dusk – and then only for a few days at a time. Most of the year it is too close to the sun for us to view it.

Venus

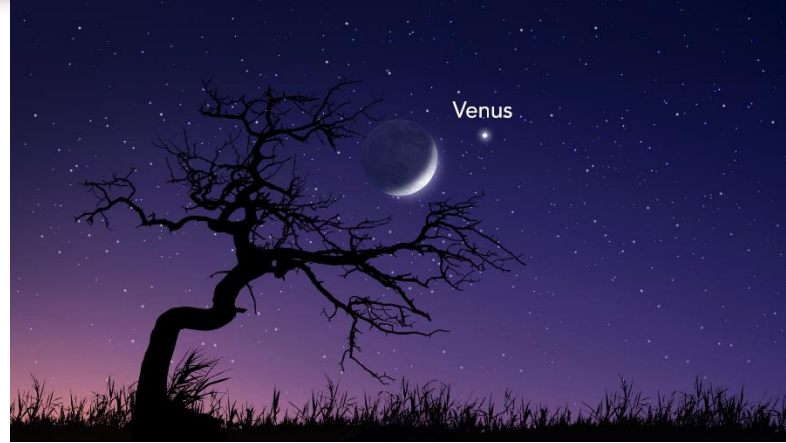

- Venus is the second planet from the Sun and the third brightest object in the sky. When Venus is in the sky it is brighter than any star.
- Sometimes known as “evening star” or “morning star”: Venus shines so intensely that it is often the first shiny dot to appear in the evening sky after sunset, or the last to disappear at dawn.
- However, Venus is not always in the sky. As it orbits around the Sun, moving behind the Sun, it moves out of our view.

Mars

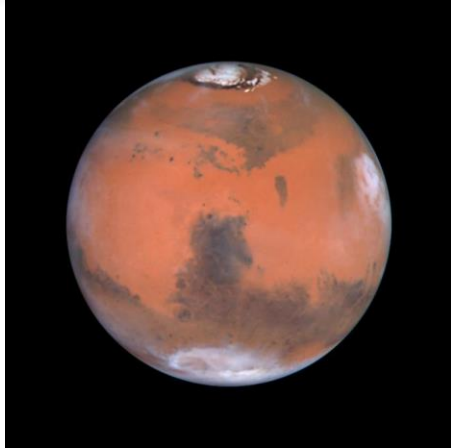

- The planet's red-orange color is a consequence of iron-oxide in its surface sands; it was this color that prompted classical astronomers to name the planet after the Roman god of war.
- Mars is nearly always visible somewhere in the sky, except for the few week's it's in conjunction and lost in the Sun's glare.
- The planet only gets close enough to Earth to give up much detail just once every 780 days

Jupiter



- Due to its large size and its high brightness, Jupiter is one of the most observed planets.
- Jupiter is thrilling to view in just about any telescope. Even a small department-store refractor will reveal several cloud belts and its four brightest moons.

Saturn



- To clearly see the rings of Saturn, you will need a telescope.
- The visual image of the planet in a telescope is often small and if the atmosphere is not steady, the image tends to ripple and blur the delicate details in the clouds and the rings



Requirement 5



Do the following:

- a. List the names of the five most visible planets. Explain which ones can appear in phases similar to lunar phases and which ones cannot, and explain why.
- b. Using the Internet (with your parent's permission), books, and other resources, find out when each of the five most visible planets that you identified in requirement 5a will be observable in the evening sky during the next 12 months, then compile this information in the form of a chart or table.
- c. Describe the motion of the planets across the sky.
- d. Observe a planet and describe what you saw.

Observing the Planets



Select object

Mar 8–Mar 9* (noon to noon)



Mercury

↓ 4:10 pm
↑ 5:55 am*



Venus

Not visible



Mars

↓ 12:56 am*
↑ 9:58 am*



Jupiter

↓ 3:55 pm
↑ 5:44 am*



Saturn

↓ 3:08 pm
↑ 5:17 am*



Uranus

↓ 10:42 pm
↑ 8:53 am*



Neptune

Not visible



Sun

↓ 6:33 pm
↑ 6:55 am*



Moon

↓ 1:30 pm
↑ 5:14 am*

* Event happens next day

- Because the planets wander around the sky and do not stay fixed in a particular location, you will need to research which planets are visible prior to your astronomical observations.
- Most guides will tell you what time and what constellation to look in.
- Click on the following link to get help in finding [Planets Visible in Your Night Sky](#).



Requirement 5



Do the following:

- a. List the names of the five most visible planets. Explain which ones can appear in phases similar to lunar phases and which ones cannot, and explain why.
- b. Using the Internet (with your parent's permission), books, and other resources, find out when each of the five most visible planets that you identified in requirement 5a will be observable in the evening sky during the next 12 months, then compile this information in the form of a chart or table.
- c. Describe the motion of the planets across the sky.
- d. Observe a planet and describe what you saw.

Motion of the Planets



- The word planet comes from the Greek word *planetes*, meaning “wanderer.”
- From night to night, each planet shifts its position slightly eastward in relation to the stars, traveling “through” various constellations over the course of several weeks as it circles the Sun.
- Sometimes, a planet exhibits *retrograde motion*—it appears to stop its eastward drift and loop back toward the west before resuming its normal west-to-east movement.
- Because Earth takes less time to orbit the Sun than outer planets like Mars, Jupiter, and Saturn, it occasionally overtakes an outer planet. As Earth approaches, the other planet appears to stop its eastward drift and loop back toward the west. As Earth swings past the planet, we see the planet resume its normal west-to-east drift in the night sky.



Requirement 5



Do the following:

- a. List the names of the five most visible planets. Explain which ones can appear in phases similar to lunar phases and which ones cannot, and explain why.
- b. Using the Internet (with your parent's permission), books, and other resources, find out when each of the five most visible planets that you identified in requirement 5a will be observable in the evening sky during the next 12 months, then compile this information in the form of a chart or table.
- c. Describe the motion of the planets across the sky.
- d. **Observe a planet and describe what you saw.**



Requirement 6



Do the following:

- a. Sketch the face of the Moon and indicate at least five seas and five craters. Label these landmarks.
- b. Sketch the phase and the position of the Moon at the same hour and place, for four nights within a one week period. Include landmarks on the horizon such as hills, trees, and buildings. Explain the changes you observe.
- c. List the factors that keep the Moon in orbit around Earth.
- d. With the aid of diagrams, explain the relative positions of the Sun, Earth, and the Moon at the times of lunar and solar eclipses, and at the times of new, first-quarter, full, and last-quarter phases of the Moon.

Moon

- The Moon is the Earth's only natural satellite and is the brightest object in the night sky.
- The Moon is in synchronous rotation with Earth, and thus always shows the same side to Earth, the near side.
- The face of the Moon is covered with mountains, plains, valleys, and is marked with craters.
- When you look at the Moon at night, you can see light areas and dark areas. The dark areas were named maria (seas) because the astronomers in the 1600s thought they were bodies of water. The light areas were named terrae (lands).



Moon

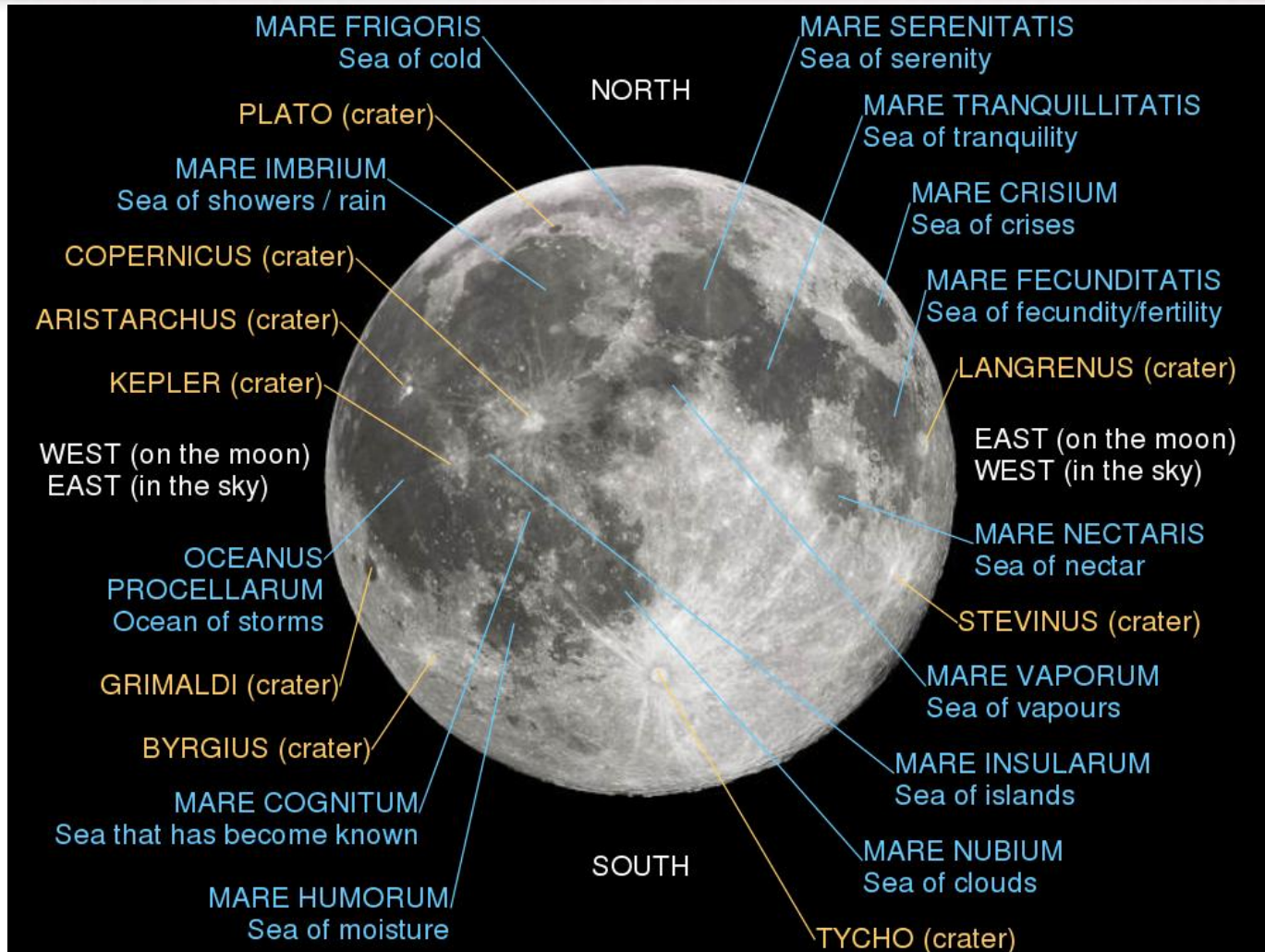



Requirement 6



Do the following:

- Sketch the face of the Moon and indicate at least five seas and five craters. Label these landmarks.
- Sketch the phase and the position of the Moon at the same hour and place, for four nights within a one week period. Include landmarks on the horizon such as hills, trees, and buildings. Explain the changes you observe.
- List the factors that keep the Moon in orbit around Earth.
- With the aid of diagrams, explain the relative positions of the Sun, Earth, and the Moon at the times of lunar and solar eclipses, and at the times of new, first-quarter, full, and last-quarter phases of the Moon.

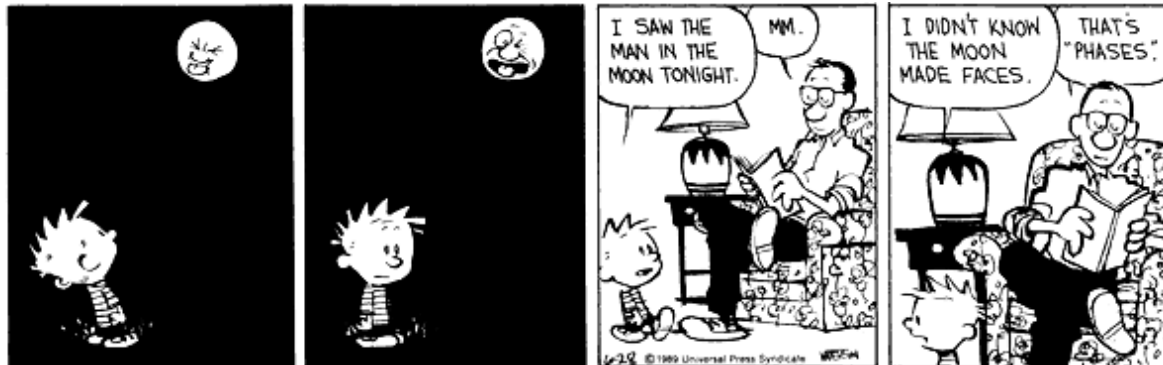

Moon Phases

- The moon takes about 29 days to make a full circuit (revolution) around the Earth.
- The Sun always illuminates the Moon, but as the Moon orbits the Earth, we cannot always see the illuminated area.
- The Moon goes through phases.
 - A moon growing to full is said to be **waxing** and as it shrinks from full to new, it is **waning**.

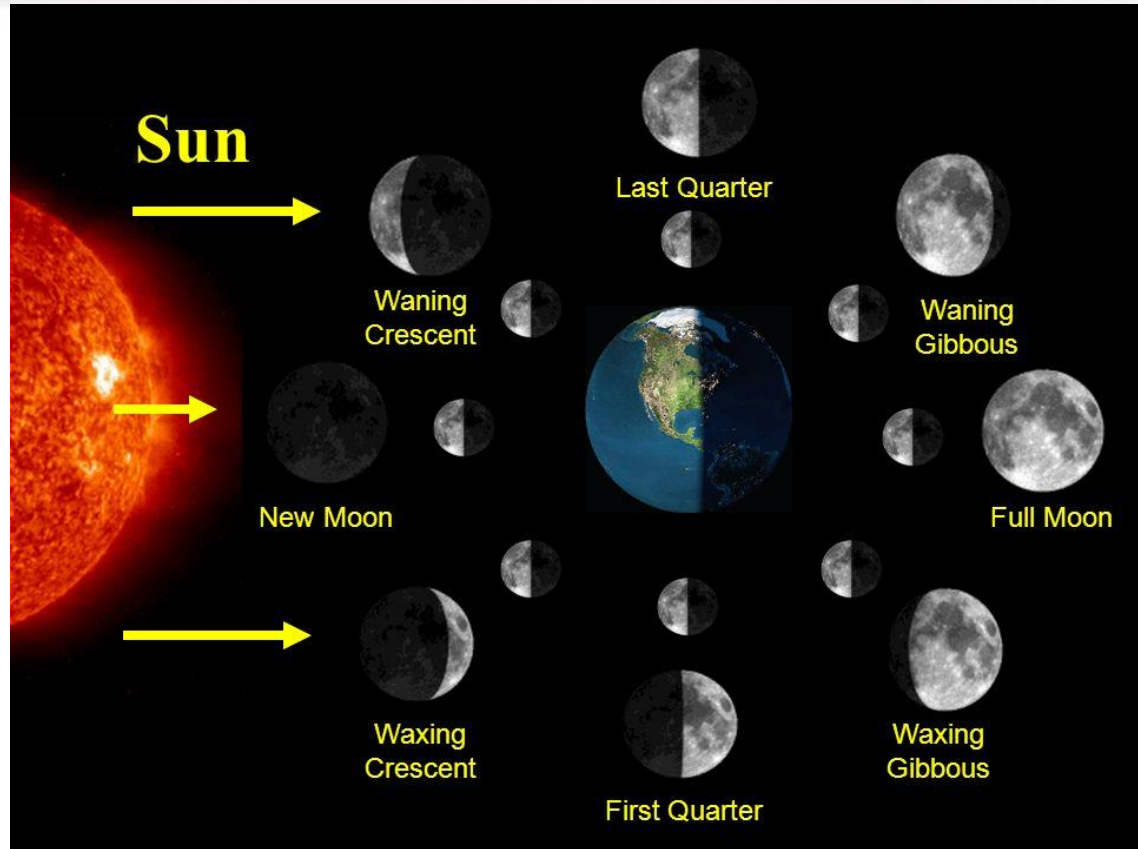



Requirement 6



Do the following:

- a. Sketch the face of the Moon and indicate at least five seas and five craters. Label these landmarks.
- b. Sketch the phase and the position of the Moon at the same hour and place, for four nights within a one week period. Include landmarks on the horizon such as hills, trees, and buildings. Explain the changes you observe.
- c. **List the factors that keep the Moon in orbit around Earth.**
- d. With the aid of diagrams, explain the relative positions of the Sun, Earth, and the Moon at the times of lunar and solar eclipses, and at the times of new, first-quarter, full, and last-quarter phases of the Moon.

Requirement 6c

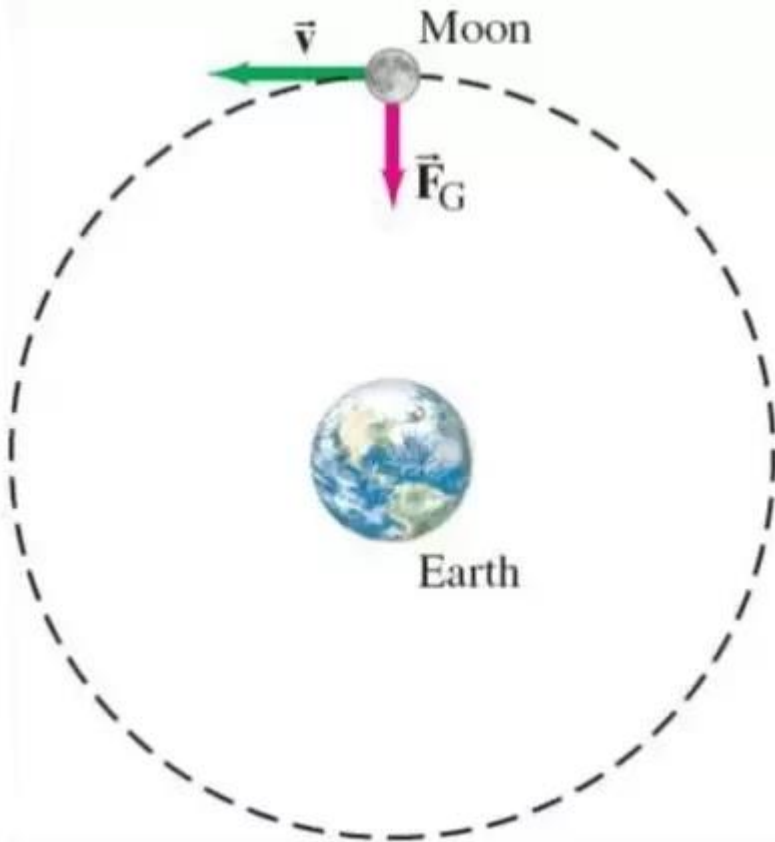

- Inertia and gravity are two forces that work to keep the Moon orbiting earth.
- Inertia is the tendency of an object in motion to continue in motion in a straight line. If the Moon traveled in a straight line, it would leave orbit and shoot off into space.
- The force that holds the Moon in its orbit is gravity. The Earth pulls the Moon towards the Earth with gravity and that keeps the Moon “falling” around Earth.



Requirement 6



Do the following:

- a. Sketch the face of the Moon and indicate at least five seas and five craters. Label these landmarks.
- b. Sketch the phase and the position of the Moon at the same hour and place, for four nights within a one week period. Include landmarks on the horizon such as hills, trees, and buildings. Explain the changes you observe.
- c. List the factors that keep the Moon in orbit around Earth.
- d. **With the aid of diagrams, explain the relative positions of the Sun, Earth, and the Moon at the times of lunar and solar eclipses,** and at the times of new, first-quarter, full, and last-quarter phases of the Moon.

Eclipses

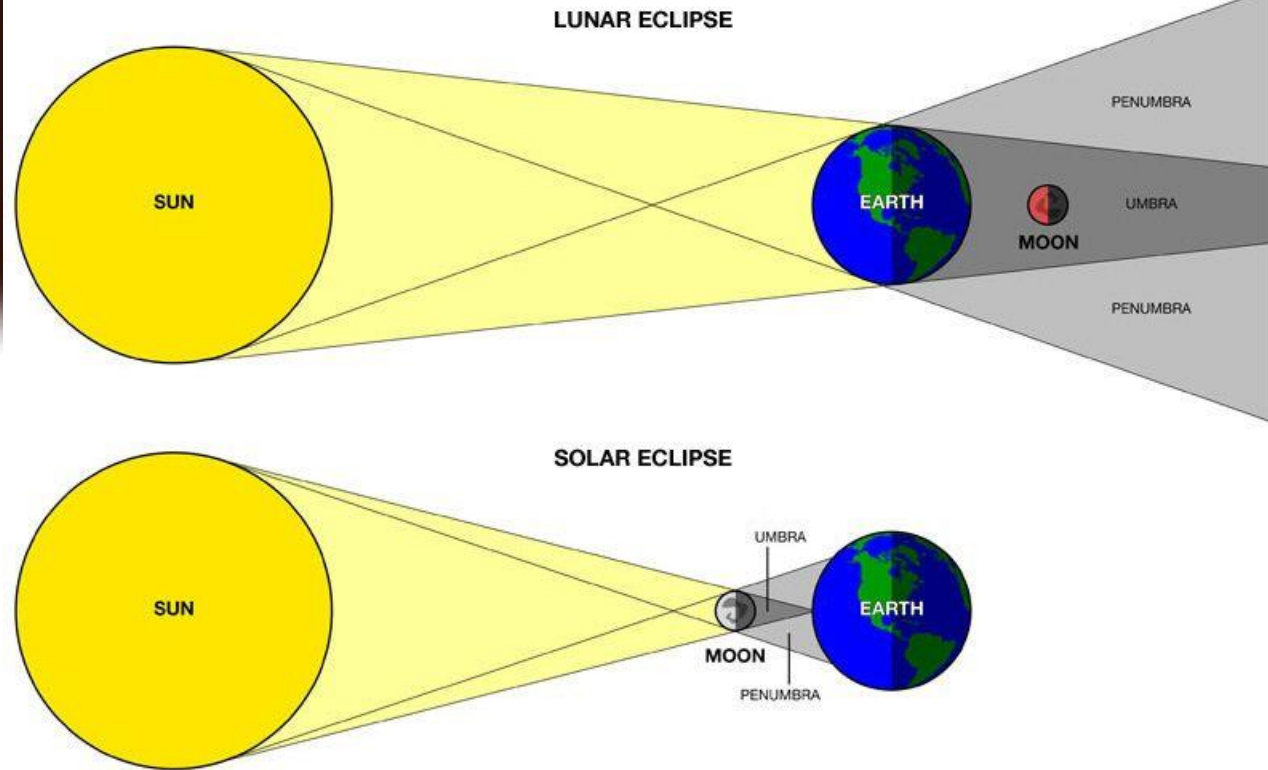

- An eclipse happens when the Moon moves directly into line with the Earth and the Sun. Eclipses only happen during the New Moon or Full Moon, and only when the Moon is in the Earth's orbital plane.
- There are two types of eclipses: Lunar eclipses and solar eclipses.
 - Lunar Eclipse: The Moon passes directly behind the Earth, passing into the Earth's shadow.
 - Solar Eclipse: The Moon passes directly between the Earth and the Sun so that the Moon's shadow strikes the Earth. During a total solar eclipse, the light from the Sun is completely blotted from view.

Eclipses

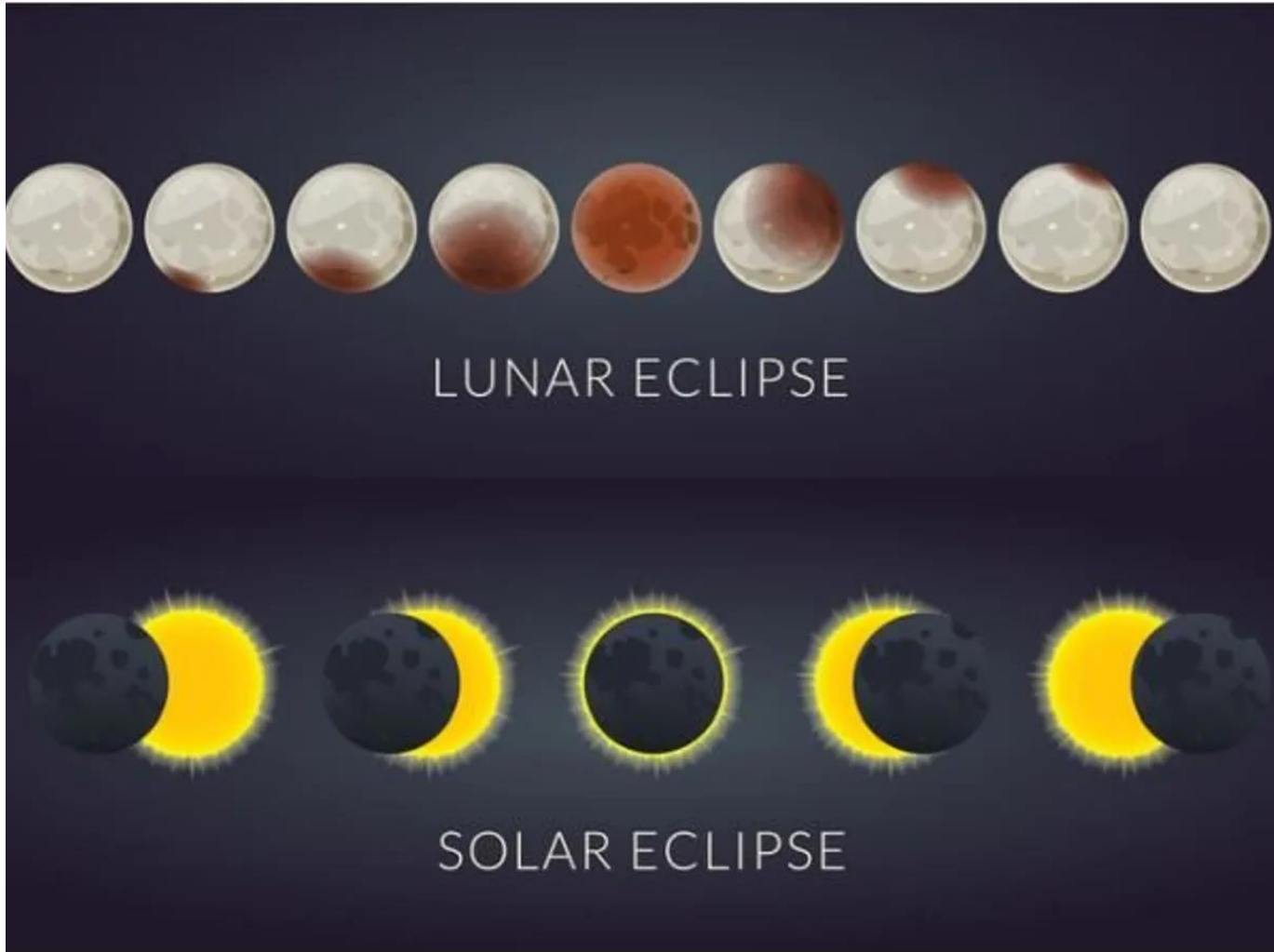

LUNAR ECLIPSE

SOLAR ECLIPSE



Requirement 7



Do the following:

- a. Describe the composition of the Sun, its relationship to other stars, and some effects of its radiation on Earth's weather and communications.
- b. Define sunspots and describe some of the effects they may have on solar radiation.
- c. Identify at least one red star, one blue star, and one yellow star (other than the Sun). Explain the meaning of these colors.

Sun

- The Sun is a huge ball of hot gas about 93 million miles from Earth.
- It contains 99.86 percent of the mass of the entire solar system.
- The Sun, like most stars, is made mainly of hydrogen and helium.
- Energy is released at a star's core as hydrogen changes into helium during nuclear fusion reactions.

The *photosphere* is the Sun's outer surface—the visible layer from which most of the Sun's radiation and light escape.

In the *convective zone*, energy is carried by rising and falling currents of hot gas called *convective cells*.

The *radiative zone* is the section where energy leaves the core.

The *core* is the center of the Sun, where nuclear reactions take place. The temperature at the core is close to 29 million degrees. The core occupies 2 percent of the Sun's volume but has 60 percent of its mass.

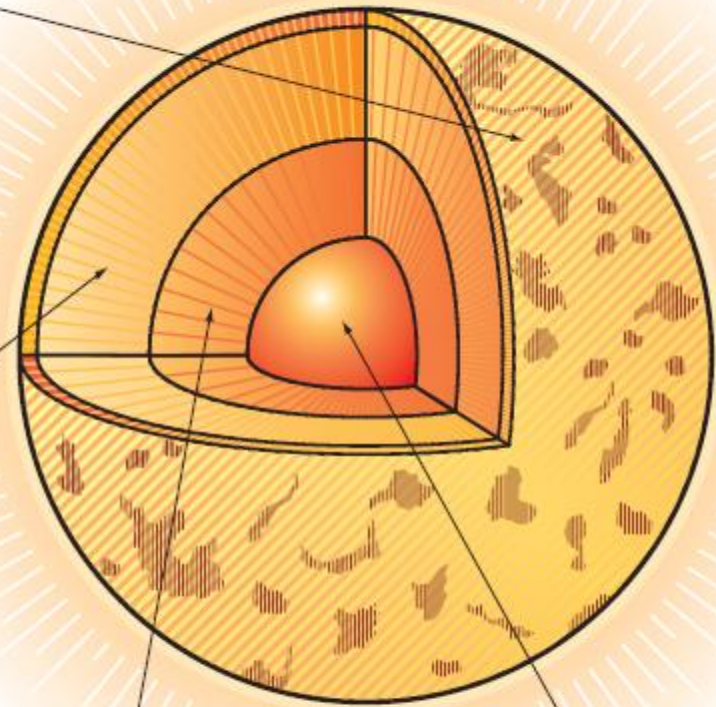

Sun

- The Sun's energy drives weather and climate on Earth.
- It burns off Earth's moisture by evaporation, heats the atmosphere, and creates wind when one air mass becomes hotter than another.
- Clouds condense from water vapor that has evaporated from the oceans, and rain from these clouds returns water to the oceans.

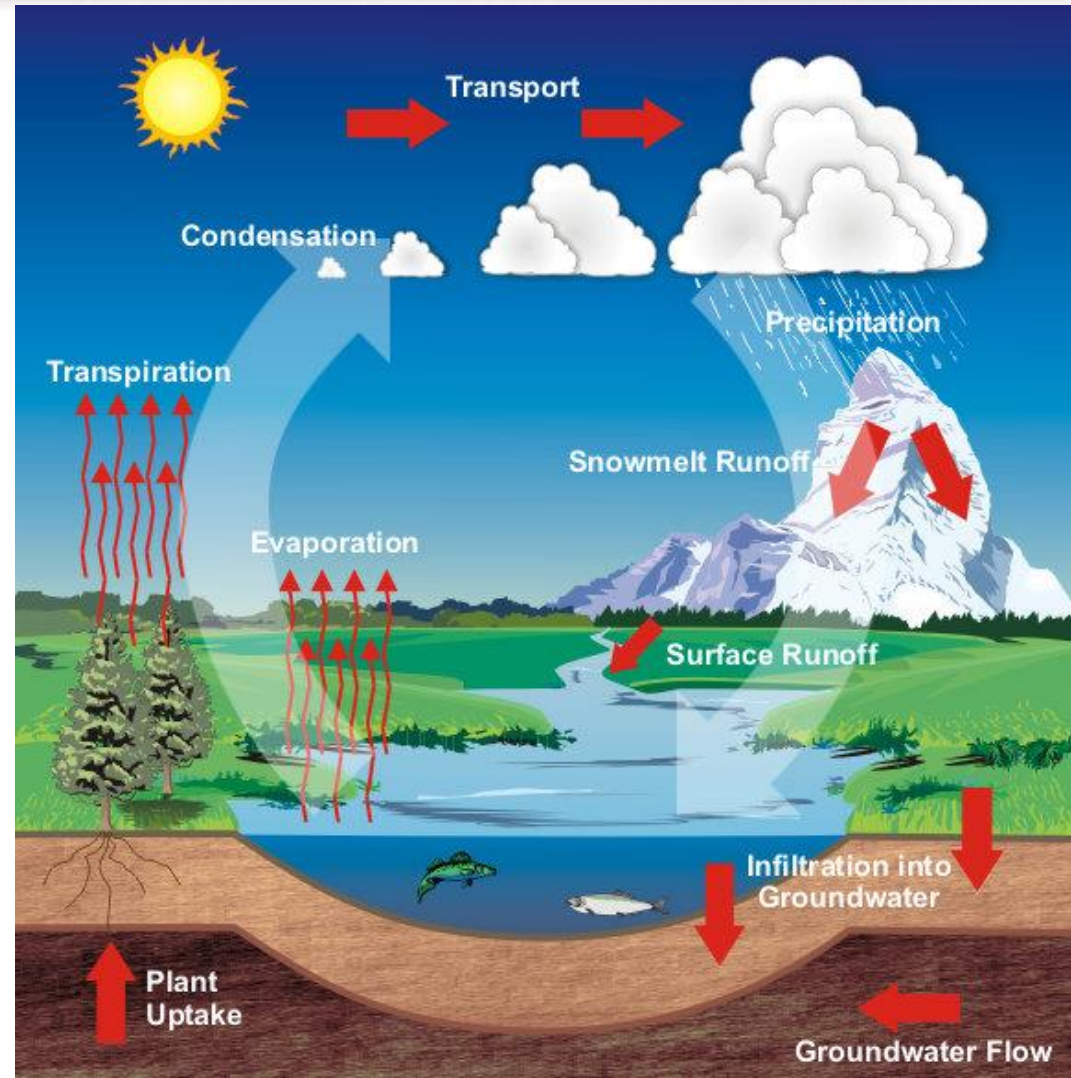

Sun

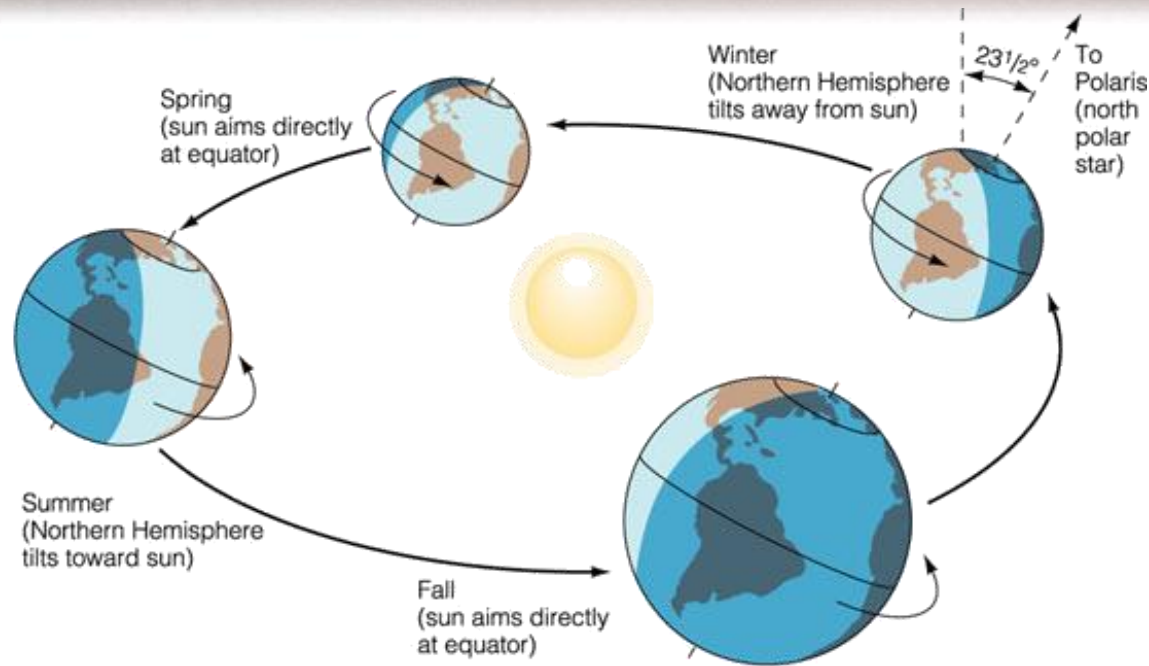

- The Earth has seasons due to its tilted axis.
- The northern hemisphere is tilted towards the Sun during the summer and gets more direct sunlight thus receiving and retaining more heat.
- Six months later, in winter, the northern hemisphere is tilted away from the sun and gets less direct sunlight thus receiving and retaining less heat.



Requirement 7



Do the following:

- a. Describe the composition of the Sun, its relationship to other stars, **and some effects of its radiation on Earth's weather and communications.**
- b. **Define sunspots and describe some of the effects they may have on solar radiation.**
- c. Identify at least one red star, one blue star, and one yellow star (other than the Sun). Explain the meaning of these colors.

Sunspots



- The surface of the Sun is called the photosphere.
- **Sunspots** are cooler areas on the photosphere.
- Sunspots are not permanent features of the Sun's surface and come and go in cycles, usually over a period of about 11 years.
- Hot material near a sunspot can burst out from the Sun in what is known as a **solar flare**.
- Particles, radiation, and magnetic fields from solar flares bombard Earth.
- If the energetic flow from the Sun is strong enough, it can cause power surges, damage sensitive electronics, overload power systems on Earth, and knock out satellite transmissions like TV, radio, and other communications.

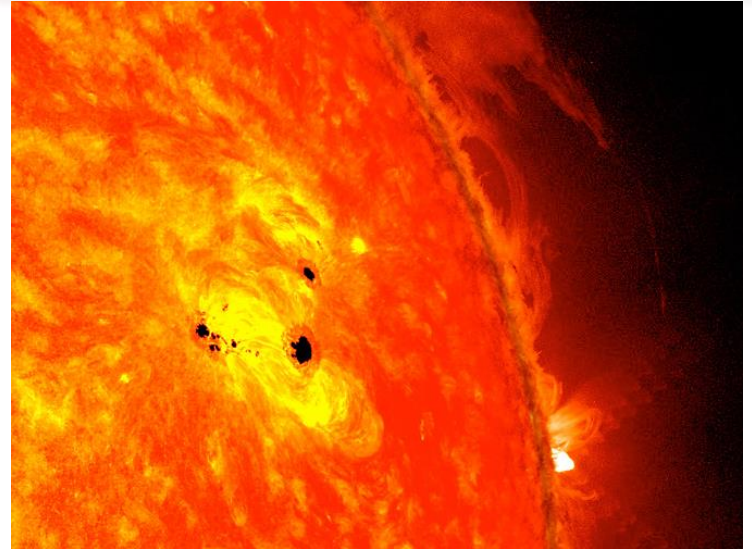



Requirement 7







Do the following:

- a. Describe the composition of the Sun, its relationship to other stars, and some effects of its radiation on Earth's weather and communications.
- b. Define sunspots and describe some of the effects they may have on solar radiation.
- c. Identify at least one red star, one blue star, and one yellow star (other than the Sun). Explain the meaning of these colors.

Star Quality



A Colorful Universe: Star Color and Temperature Fall/Winter

Color	Example	Surface Temperature (°C)
	Rigel (Orion)	28,000–11,000
	Sirius (Canis Major)	11,000–7,500
	Sun & Capella (Auriga)	6,000–5000
	Aldebaran (Taurus)	5,000–3,600
	Betelgeuse (Orion)	3,600–2,000

- Stars are divided into color categories, from hottest to relatively coolest: blue and blue-white, white, yellow, orange, and red.
- Stars are referred to this way because they appear to be these colors when observed through a telescope.



Requirement 8



8. With your counselor's approval and guidance, do ONE of the following:
- a. Visit a planetarium or astronomical observatory. Submit a written report, a scrapbook, or a video presentation afterward to your counselor that includes the following information:
 1. Activities occurring there
 2. Exhibits and displays you saw
 3. Telescopes and instruments being used
 4. Celestial objects you observed.
 - b. Plan and participate in a three-hour observation session that includes using binoculars or a telescope. List the celestial objects you want to observe, and find each on a star chart or in a guidebook. Prepare a log or notebook. Discuss with your counselor what you hope to observe prior to your observation session. Review your log or notebook with your counselor afterward.**
 - c. Plan and host a star party for your Scout troop or other group such as your class at school. Use binoculars or a telescope to show and explain celestial objects to the group.
 - d. Help an astronomy club in your community hold a star party that is open to the public.
 - e. Personally take a series of photographs or digital images of the movement of the Moon, a planet, an asteroid, meteor, or a comet. In your visual display, label each image and include the date and time it was taken. Show all positions on a star chart or map. Show your display at school or at a troop meeting. Explain the changes you observed.

Planetariums

- The Bowling Green State University Planetarium is a 114-seat public science theater serving BGSU students, area schools, and the public of northwest Ohio.
- Public planetarium programs are open to all and are given from September through early May each year. Programs feature a star talk showing the current evening sky followed by a multimedia planetarium show. Weekend programs are followed by stargazing at the Observatory on the roof, weather permitting.
- Address: 112 Physical Sciences Lab Building, Bowling Green, OH 43403
- Phone: (419) 372-2421



Astronomy Clubs Near Me



- What are the astronomy clubs near you and how do you find them?"
- [Sky & Telescope](#) helps you to contact your local astronomy club, where you'll find like-minded enthusiasts eager to share their knowledge and love of the sky with you.
- Club meetings offer opportunities to try out new equipment, learn new techniques, and make new friends.
- In addition to finding astronomy clubs near you, you will also find planetariums, observatories, museums, and other great resources, all of which appear in the Sky & Telescope directory of clubs and organizations.

**SKY &
TELESCOPE**

Plan an Observing Session

- Develop an observing plan for a session when you will set up a telescope or observe with binoculars.
- Assemble the charts and guidebooks you will need.
- Prepare a red-filtered flashlight so you can view your charts without impairing your night vision.
- Get a notebook or create an observing log.
- Be sure to check the weather forecast and dress appropriately. Even in mild seasons like the spring, nights can get cold. It pays to have extra layers as well as gloves, a scarf, and a hat.
- Scout out the area beforehand to make sure you are aware of any conditions or potential hazards on the ground that you might miss when you come back at night.



Plan and Host a Star Party

- Plan to do everything you did for your own observing session, plus more.
- Find a good date and a place with plenty of room for the number of people you want to invite.
- Considering the time of year and how far north you live, develop a list of space objects you wish to find during the star party.
- Consider inviting Scouts in your troop, your neighbors, family and friends, classmates, and teachers.
- When you invite them, be sure to cover such subjects as weather and proper dress, observing etiquette, and safety.
- Encourage those who have binoculars to bring them.



Help with a Public Star Party



- Contact a local astronomy organization or club to volunteer to help with a public star party. If you are unsure whom to contact, ask at a college in your community.



Requirement 9



9. Find out about three career opportunities in astronomy. Pick one and find out the education, training, and experience required for this profession. Discuss this with your counselor, and explain why this profession might interest you.

Astronomy Careers

- Most astronomers teach at colleges and universities and also do some research in a particular area of astronomy, such as planetary science, solar astronomy, or the study of stars or galaxies. Often, those who teach astronomy also teach physics.
- About a third of professional astronomers have careers in federal government or at government-supported national observatories and laboratories.
- About 10 percent of astronomers are employed in business or private industry like the aerospace field.
- Click on the link for information about [10 Popular Astronomy Jobs That Pay Well](#)

