

NATURE MERIT BADGE



Troop 344 and 9344
Pemberville, OH



Nature Merit Badge Requirements



1. Name three ways in which plants are important to animals. Name a plant that is important to animals that is protected in your state or region, and explain why it is at risk.
2. Name three ways in which animals are important to plants. Name an animal that is protected in your state or region, and explain why it is at risk.
3. Explain the term "food chain." Give an example of a four-step land food chain and a four-step water food chain.

Nature Merit Badge Requirements



4. Do all the requirements in FIVE of the following fields:
 - a. BIRDS
 1. In the field, identify eight species of birds.
 2. Make and set out a birdhouse OR a feeding station OR a birdbath. List what birds used it during a period of one month.
 - b. MAMMALS
 1. In the field, identify three species of wild mammals.
 2. Make plaster casts of the tracks of a wild mammal.
 - c. REPTILES and AMPHIBIANS
 1. Show that you can recognize the venomous snakes in your area.
 2. In the field, identify three species of reptiles or amphibians.
 3. Recognize one species of toad or frog by voice;
OR identify one reptile or amphibian by eggs, den, burrow or other signs.

Nature Merit Badge Requirements



4. Do all the requirements in FIVE of the following fields:
 - d. INSECTS and SPIDERS
 1. Collect and identify either in the field or through photographs 10 species of insects or spiders.*
 2. Hatch an insect from the pupa or cocoon;
OR hatch adults from nymphs;
OR keep larvae until they form pupae or cocoons;
OR keep a colony of ants or bees through one season.
 - e. FISH
 1. Identify two species of fish native to your area.
 2. Collect four kinds of animal food eaten by fish in the wild.
 - f. MOLLUSKS AND CRUSTACEANS
 1. Identify five species of mollusks and crustaceans.
 2. Collect, mount, and label six shells.

Nature Merit Badge Requirements



4. Do all the requirements in FIVE of the following fields:

g. PLANTS

1. In the field, identify 15 species of wild plants.
2. Collect and label seeds of six plants;
OR the leaves of 12 plants.

h. SOILS AND ROCKS

1. Collect and identify soils found in different layers of a soil profile.
2. Collect and identify five different types of rocks from your area.

Requirement 1



Name three ways in which plants are important to animals. Name a plant that is protected in your state or region, and explain why it is at risk.



Requirement 1

1. Plants produce the oxygen that animals breathe.

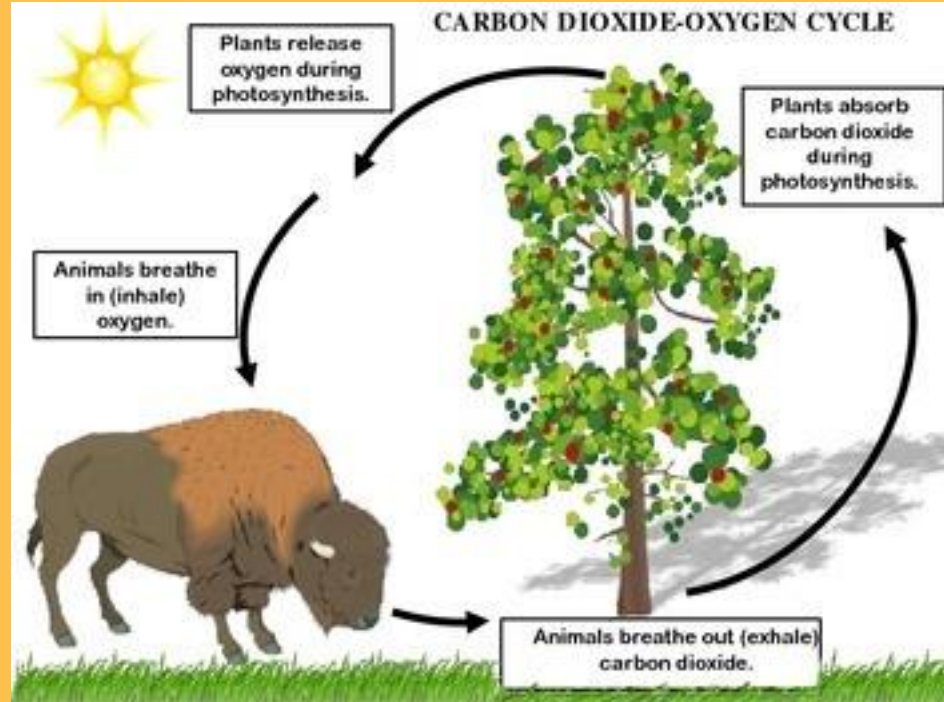

Requirement 1

2. Plants are the base of the food chain for all animals.

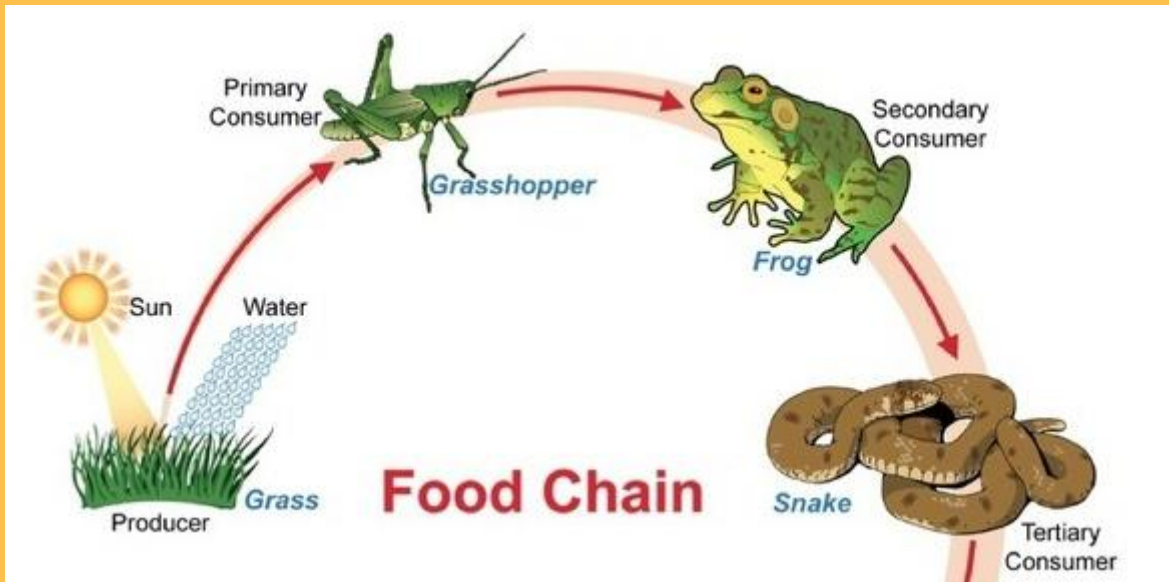

Requirement 1

3. Plants provide shelter and nesting habitat for many animals.



Requirement 1

Endangered Plants in Ohio

There are six plant species classified as endangered in Ohio.

1. Running Buffalo Clover
2. Northern Monkshood
3. Lakeside Daisy
4. Small Whorled Pogonia
5. Eastern Prairie White Fringed Orchid
6. Appalachian Spiraea

These plants are endangered in Ohio from over-collecting, destruction of habitat, and competing invasive plants.

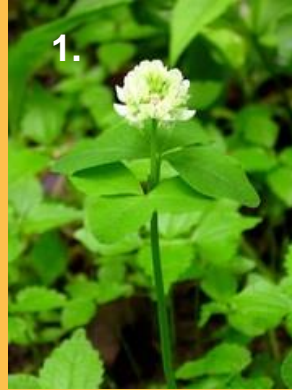

Requirement 2



Name three ways in which animals are important to plants.
Name an animal that is protected in your state or region, and explain why it is at risk.



Requirement 2

1. Animals release carbon dioxide which plants take in during photosynthesis.

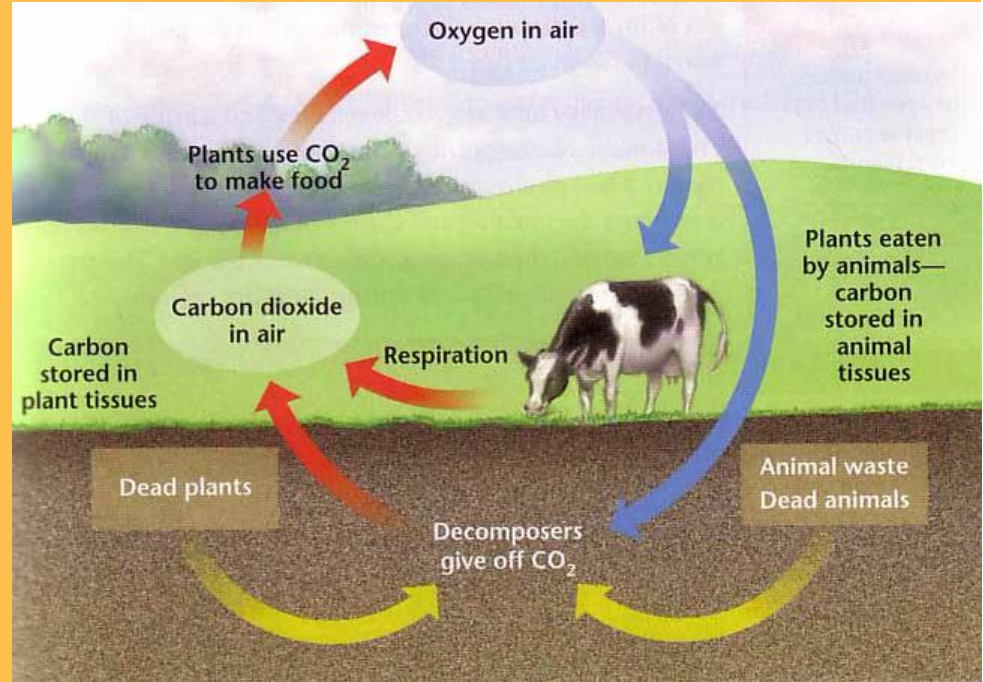

Requirement 2

2. Animals help pollinate many plants



Requirement 2

3. Animals help disperse the seeds of many plants.



Requirement 2

- Animals fertilize the soil for plants during defecation, urination, and decomposition upon death.

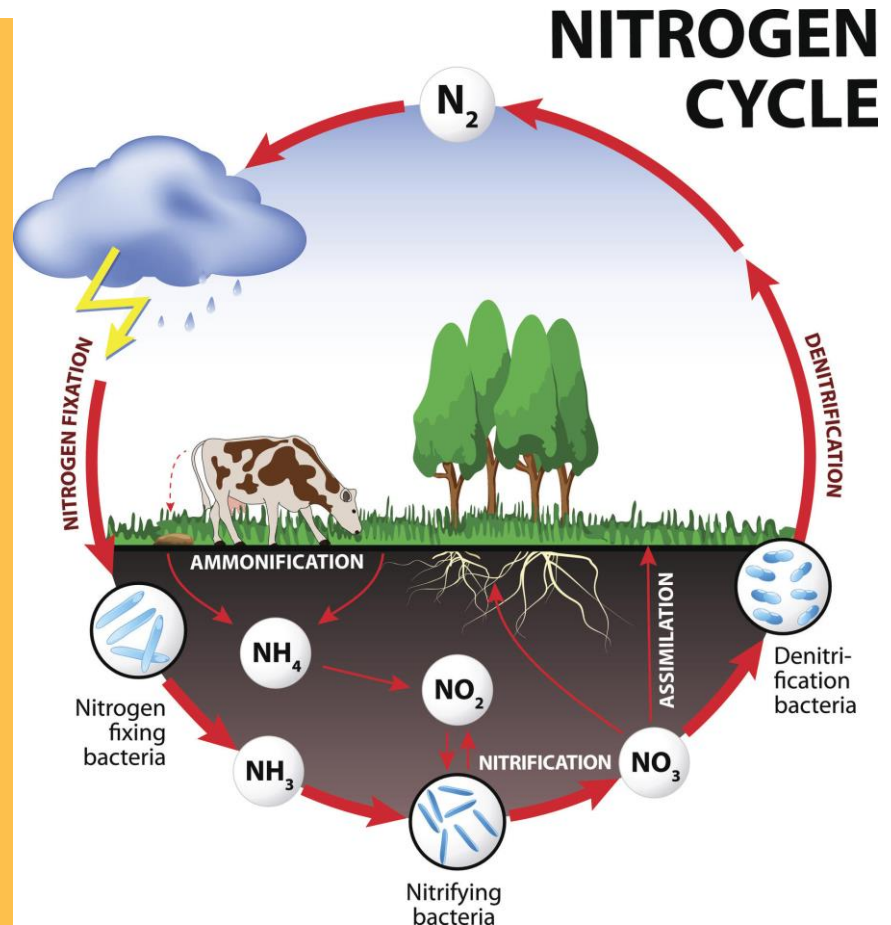

Requirement 2

Click on the following link for the full list of the 19 Endangered Animals in Ohio.

The major reason for the decline of most of these species is the loss of habitat.



Allegheny Woodrat



Indiana Bat



Karner Blue Butterfly



Green Salamander



Sandhill Crane

Requirement 3



Explain the term "food chain."
Give an example of a four-step
land food chain and a four-step
water food chain.

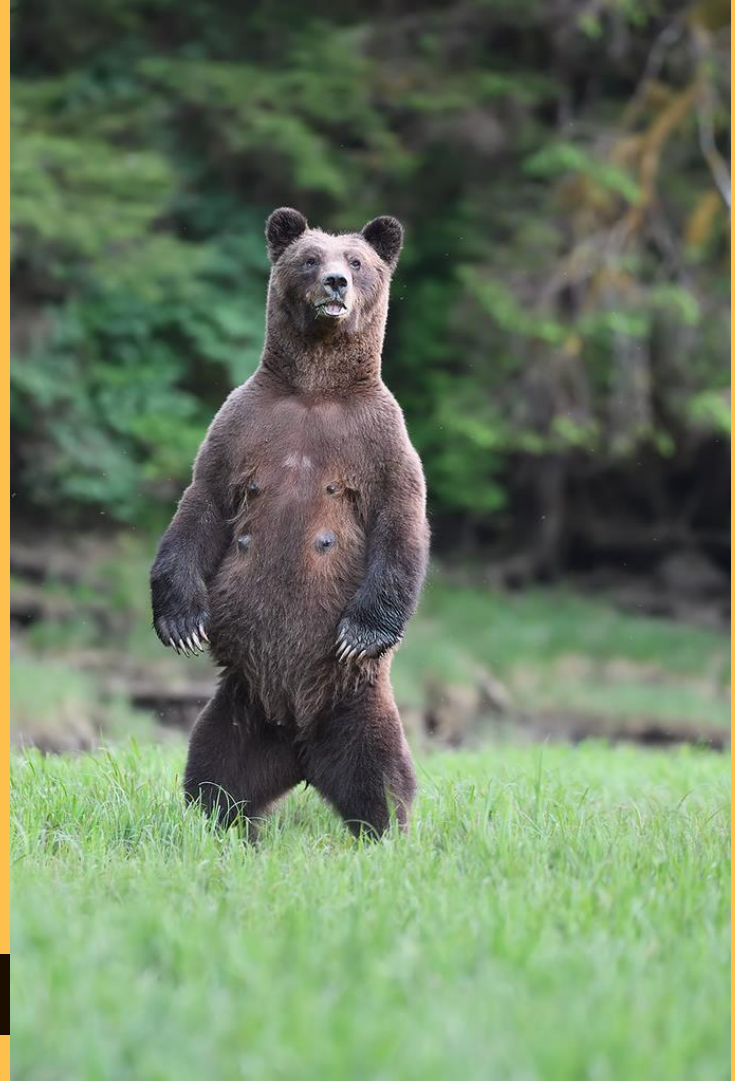

Requirement 3

In ecology, a *food chain* is a series of organisms that eat one another so that energy and nutrients flow from one to the next. *Food chains* intertwine locally into a *food web* because most organisms consume more than one type of animal or plant.

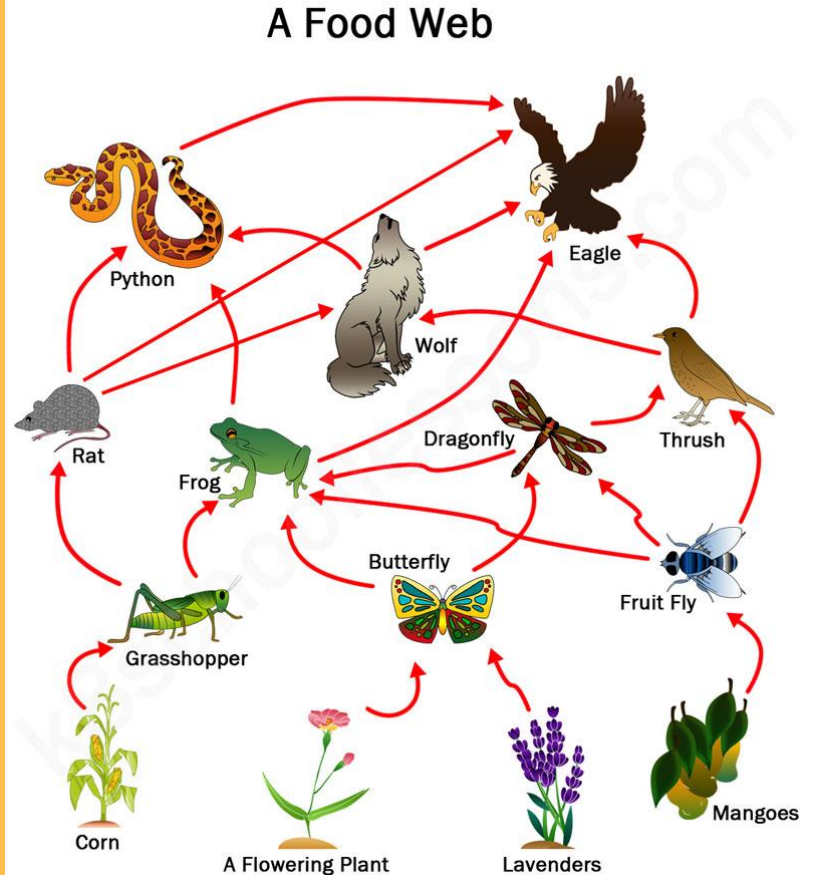

Requirement 3

Terrestrial Food Chain

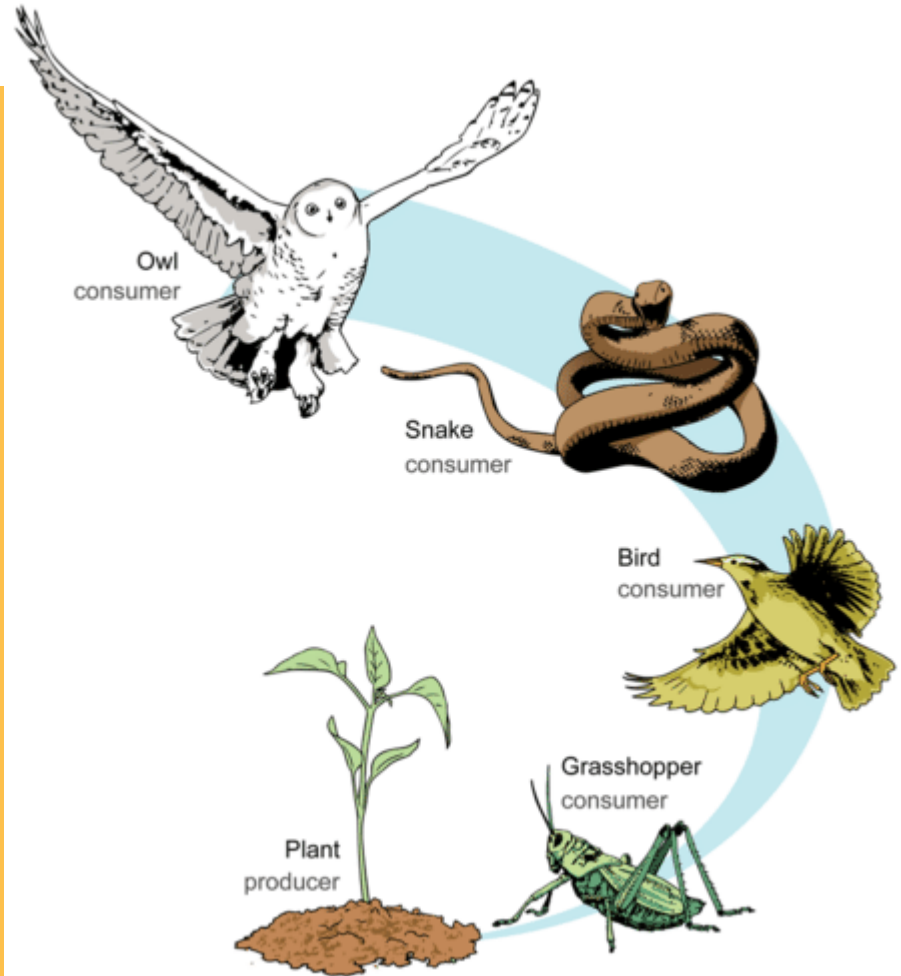

Requirement 3

Aquatic Food Chain

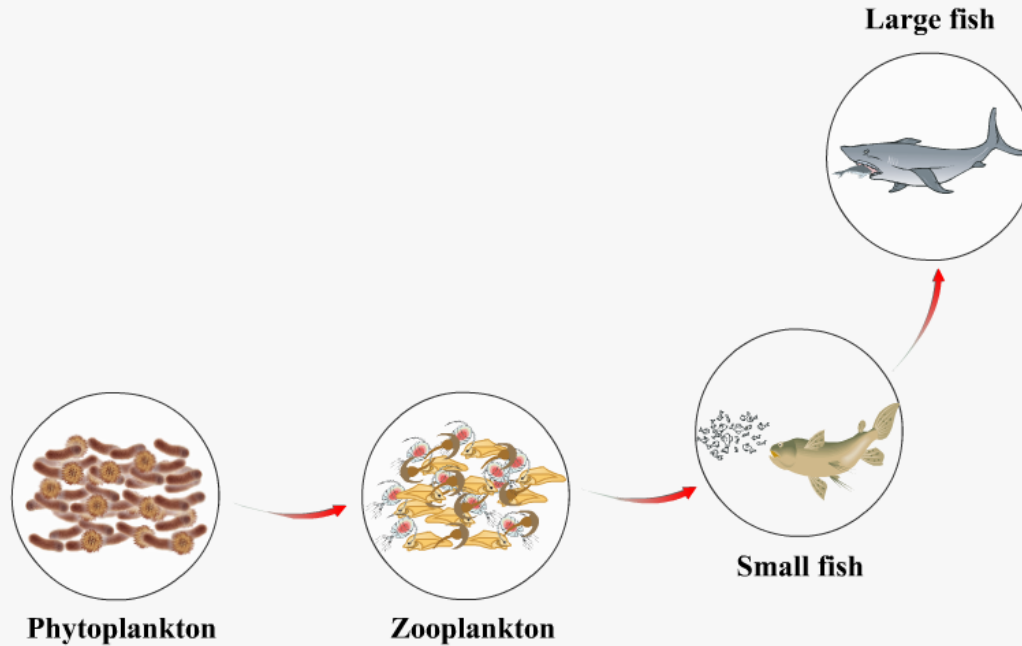

Requirement 4



Field guides to use for meeting the identification requirements of Requirement 4 can typically be found in your local library.

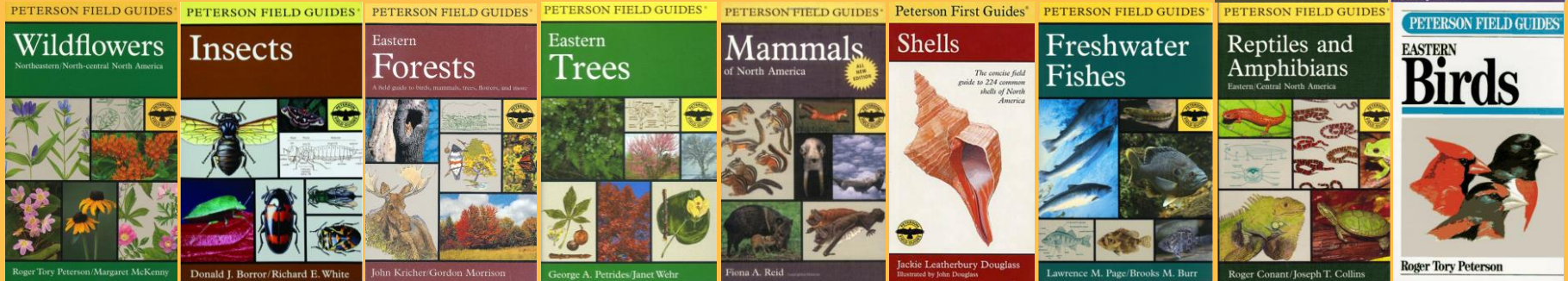

Requirement 4a



4. Do all the requirements in FIVE of the following fields:

a. BIRDS

1. In the field, identify eight species of birds.
2. Make and set out a birdhouse OR a feeding station OR a birdbath. List what birds used it during a period of one month.

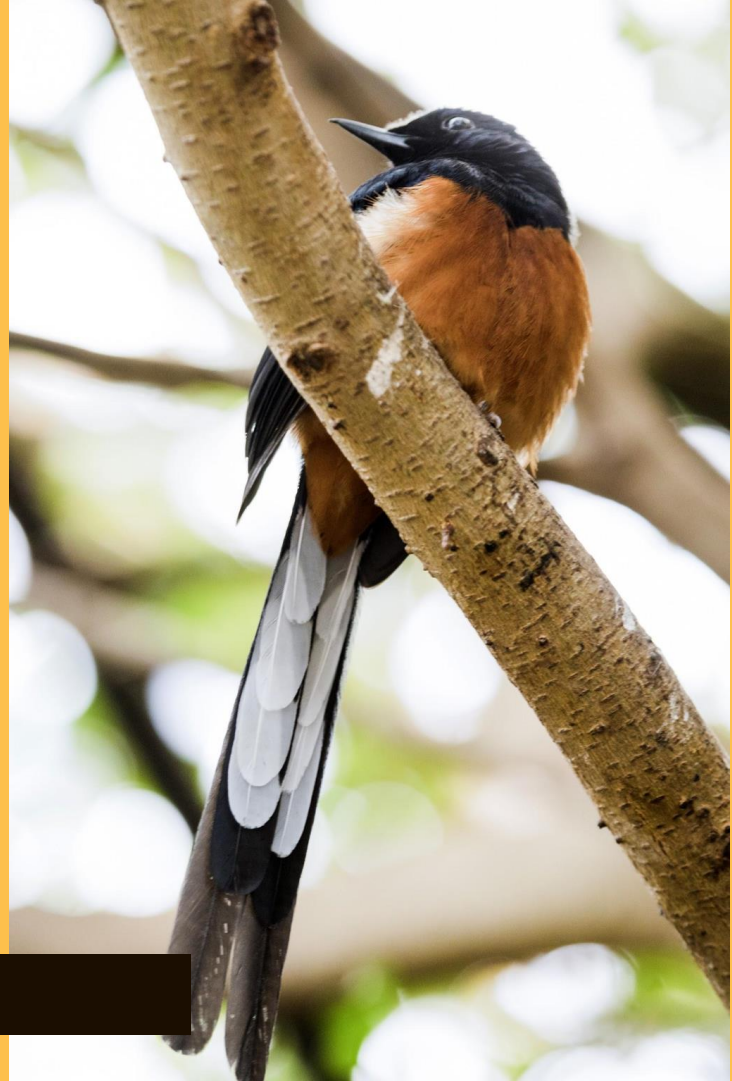

EASTERN BLUEBIRD NEST BOX

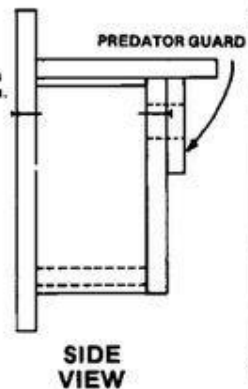
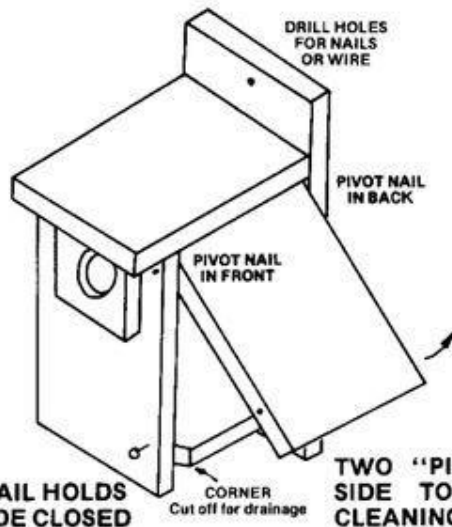
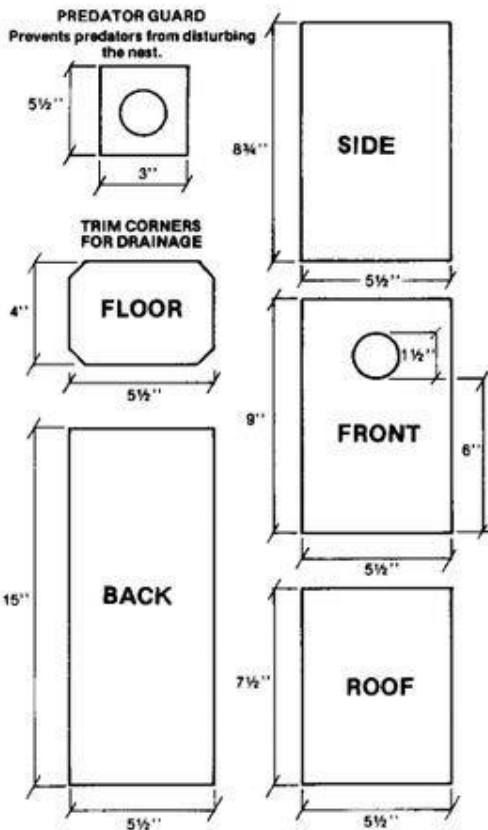

TWO "PIVOT" NAILS ALLOW SIDE TO SWING OUT FOR CLEANING. USE ONE NAIL AT BOTTOM TO CLOSE SIDE.

LUMBER: ONE 1" x 6" x 6'

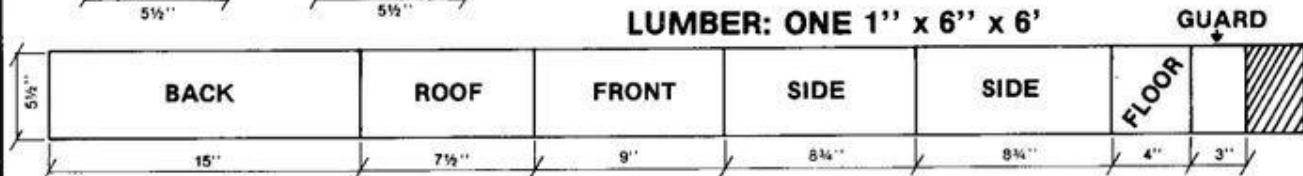

Requirement 4b



4. Do all the requirements in FIVE of the following fields:

b. MAMMALS

1. In the field, identify three species of wild mammals.
2. Make plaster casts of the tracks of a wild mammal.



Requirement 4b

Making plaster casts of the tracks of a wild mammal.

1. It is easy to make casts of animal tracks. All you need is a 2-liter soda bottle cut into 2 inch sections and some plaster of Paris.
2. First locate a track with clean features. Look in damp or sandy areas where the soil is soft. Being careful not to alter the track imprint, remove any debris or loose soil from the track. Then place the soda bottle ring over the track and press it lightly into the soil to seal it.
3. Next, mix 1/4 to 1/2 cup plaster of Paris with water until the consistency is similar to pancake batter. Pour the plaster into the plastic ring, covering the track and filling to a depth of about 1”.
4. Let the plaster dry at for least 1 hour before moving the ring. After the plaster dries for 24 hours, you can remove it from the ring.

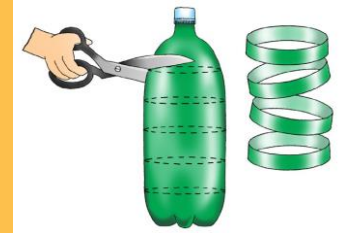

Guide To Animal Tracks

F - front track
H - hind track
T - tail marks may be present

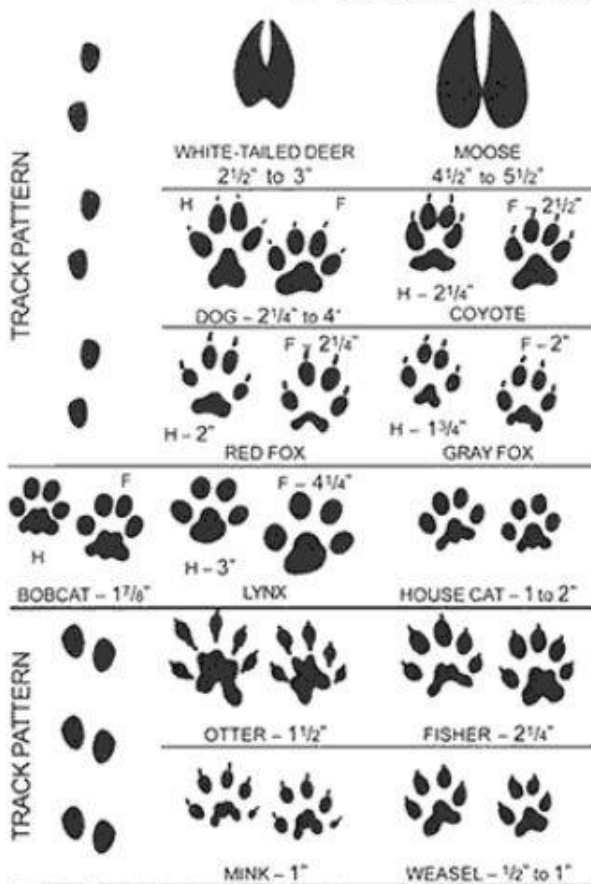

Tracks are not to scale

TRACK PATTERN

TRACK PATTERN

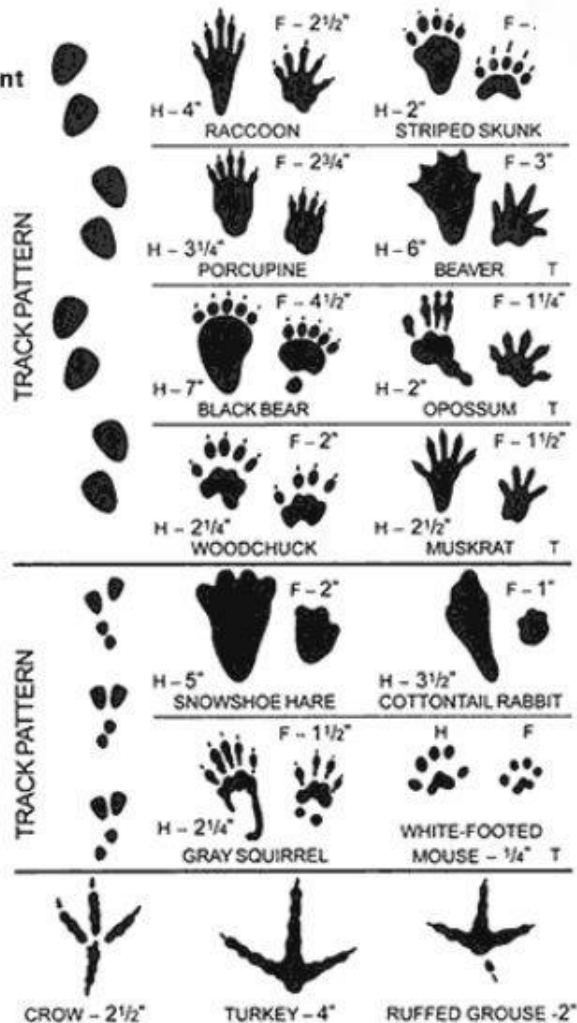

Requirement 4c



4. Do all the requirements in FIVE of the following fields:

c. REPTILES and AMPHIBIANS

1. Show that you can recognize the venomous snakes in your area.
2. In the field, identify three species of reptiles or amphibians.
3. Recognize one species of toad or frog by voice;
OR identify one reptile or amphibian by eggs, den, burrow or other signs.



Requirement 4c

Venomous Snakes of Ohio

Northern Copperhead

- It loves to eat small rodents (like mice), but it will also go after frogs, small snakes, small birds, and insects.
- Female copperheads have a territory of around eight acres while the males may roam up to 24 acres.
- Watch for them around old buildings, old logging sawmill slab piles, rock crevices, and areas bordering swamps.
- They are year-round residents of Eastern and Southern Ohio.

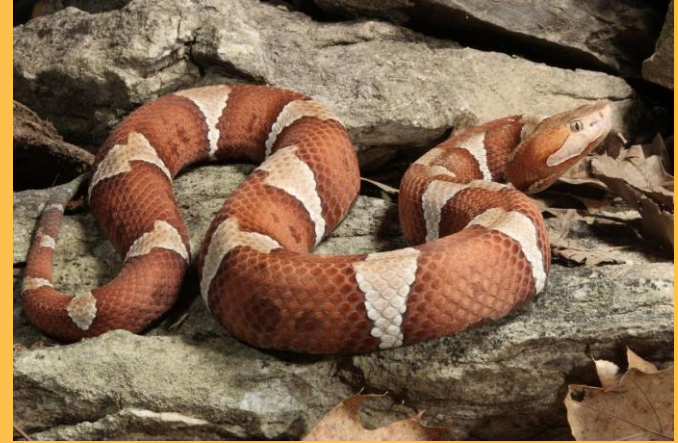

Requirement 4c

Venomous Snakes of Ohio

Massasauga Rattlesnake

- The Eastern Massasauga Rattlesnake is named after a combination of two words from the language of the Chippewa tribe of Native Americans.
- They prefer to stay hidden and are found in wet prairies, early succession fields, and sedge meadows.
- These Ohio year-long residents hibernate in small groups in moist soil.
- Young birds, shrews, mice, voles, salamanders, and other small species are regular meals for this recluse.



Requirement 4c

Venomous Snakes of Ohio

Timber Rattlesnake

- Timber Rattlesnakes are found in wooded areas and will sun themselves where the sunlight penetrates the leaf canopy.
- Deep rock crevices are their preferred hibernating areas and den sites.
- Squirrels, chipmunks, rats, and mice are often on the menu for the Timber Rattler.
- Timber Rattlesnake are found mostly in the northern half of the state.



Requirement 4d



4. Do all the requirements in FIVE of the following fields:

d. INSECTS and SPIDERS

1. Collect and identify either in the field or through photographs 10 species of insects or spiders.*
2. Hatch an insect from the pupa or cocoon;
OR hatch adults from nymphs;
OR keep larvae until they form pupae or cocoons;
OR keep a colony of ants or bees through one season.

*Photos may be taken with your own equipment or gathered from other sources.



Requirement 4d



Use the following link for practical tips on successfully rearing [Monarch Butterflies](#) and releasing them into the wild.

Requirement 4e



4. Do all the requirements in FIVE of the following fields:

e. FISH

1. Identify two species of fish native to your area.
2. Collect four kinds of animal food eaten by fish in the wild.

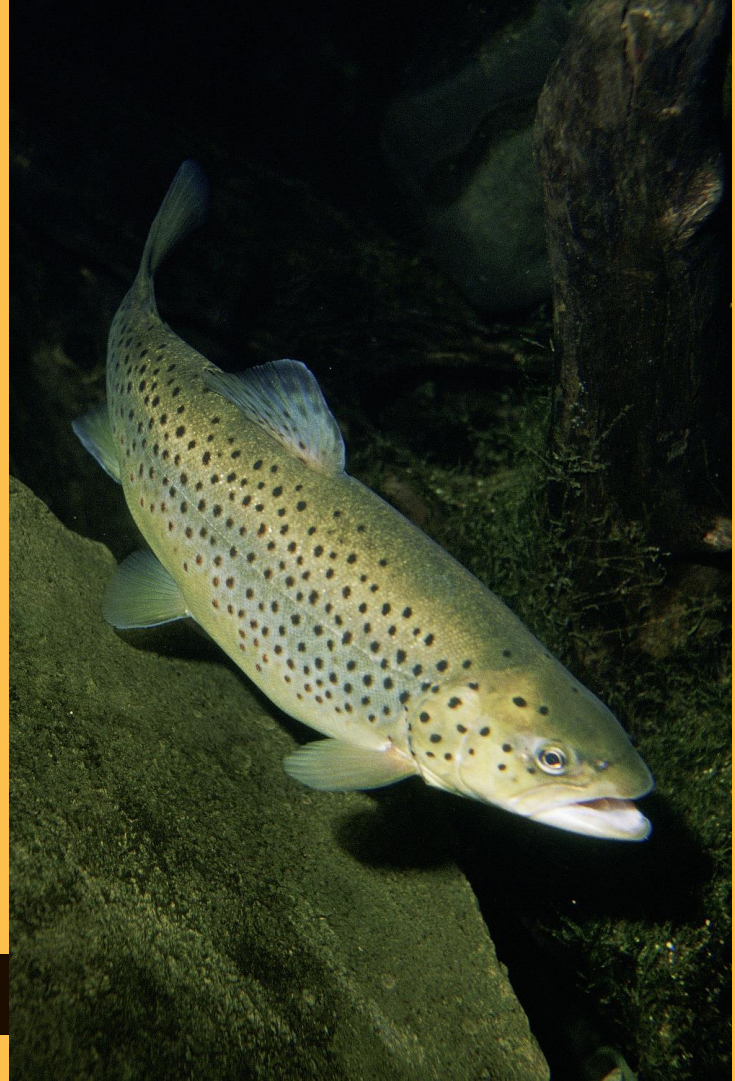

Requirement 4e

Adult fish eat crustaceans, frogs, larval and adult insects, and live fish.



Mayfly Larva and Adult



Requirement 4f



4. Do all the requirements in FIVE of the following fields:

f. MOLLUSKS AND CRUSTACEANS

1. Identify five species of mollusks and crustaceans.
2. Collect, mount, and label six shells.



Requirement 4g



4. Do all the requirements in FIVE of the following fields:

g. PLANTS

1. In the field, identify 15 species of wild plants.
2. Collect and label seeds of six plants;
OR the leaves of 12 plants.



Requirement 4h



4. Do all the requirements in FIVE of the following fields:

h. SOILS AND ROCKS

1. Collect and identify soils found in different layers of a soil profile.
2. Collect and identify five different types of rocks from your area.



Requirement 4h

Soil Profile

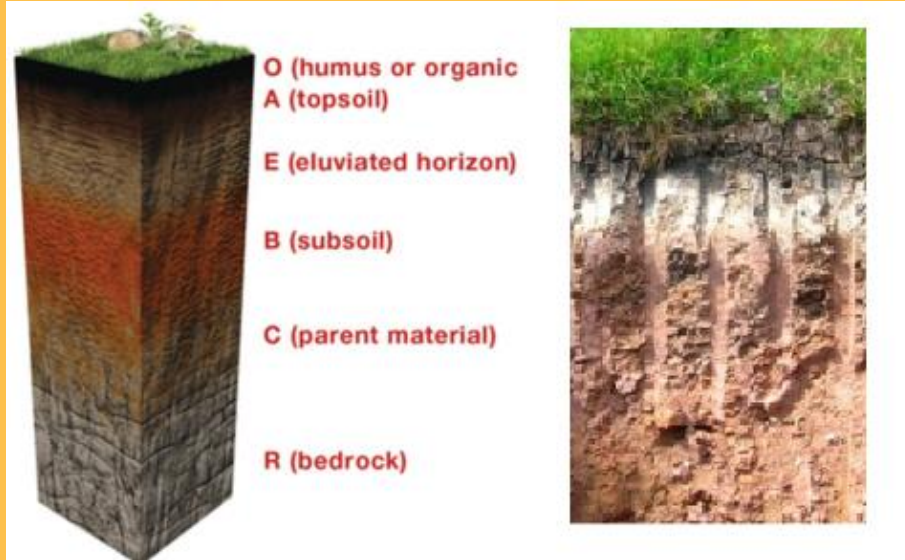



Principles of Leave No Trace

Do your part to keep nature natural by following these principles.

1. **Plan ahead and prepare.** Proper planning and preparation increases safety, reduces the impact of your visit on the environment, and helps make your outdoor experience more enjoyable.
2. **Travel and camp on durable surfaces.** Natural environments are easily damaged by foot traffic. Use existing trails or travel on durable surfaces such as rock, gravel, sand, compacted soil, dry grasses, or snow. Large groups should spread out to avoid creating new trails. Keep campsites small.
3. **Dispose of waste properly (pack it in, pack it out).** Any material people leave behind pollutes the environment and might create a health hazard for wildlife or other visitors. Pack out any trash and leftover food. Dispose of human waste by digging catholes 6 to 8 inches deep and 200 feet away from water, trails, and campsites.
4. **Leave what you find.** Observe the interesting things you find, but do not disturb them. Use established campsites and do not alter them in any way. Restore campsites to pristine condition before you leave.
5. **Minimize campfire impacts.** Use a lightweight stove when cooking in the backcountry. If you need to build a fire, keep it small and use only dead or downed wood. Never cut down limbs or trees for firewood.
6. **Respect wildlife.** Stay far enough away from animals that your presence does not disturb their natural activity. Store food, food scraps, and trash securely to prevent animals from eating food that is not part of their natural diet. Never feed wild animals.
7. **Be considerate of other visitors.** Let everyone enjoy nature. Travel and camp quietly and away from other people. Blend in by wearing subdued colors. Leave pets and portable audio devices at home.